

**SMART Gas Detector/Transmitter(4~20mA)
with built-in LCD & explosion proof**

JDA-500



CONTENTS

■ 1. Introduction	-----	page 3
■ 2. Features	-----	page 3
■ 3. Specification	-----	page 4
■ 4. Parts & Description	-----	page 5 ~ 6
■ 5. Sensor Calibration	-----	page 7 ~ 8
■ 6. Sensor Replacement	-----	page 9
■ 7. Wiring	-----	page 10
■ 8. Installation	-----	page 11 ~ 12
■ 9. Setting Menu	-----	page 13 ~ 15
■ 10. Sensor Calibration Menu	-----	page 16 ~ 17

1> Introduction

JDA-500 detects various combustible & toxic gases leaked from industrial areas for gas producers, gas users, gas reservoirs, gas by-producers, and so on, in order to prevent any accidents in advance. JDA-500 converts digital signal into the 4-20mA standard current output signal which can be transmitted to various devices such as PLC, DDC, or recorder to build comprehensive gas monitoring system. Also, JDA-500 provides RS-485 communication signal and alarm relay contact. DC 4-20mA standard output signal realizes max 2500m long distance output signal transmission and RS-485 communication signal realizes max 1000m long distance signal transmission.

2> Features

- Digital process
Digital processor based on built-in micro processor realizes various artificial intelligent functions which result in convenient gas monitoring environment.
- Self diagnosis
Digital process automatically diagnoses the sensor signal and sends 2mA error signal output on the malfunction in the sensor.
- Auto-calibration without opening cover
You don't need to open front cover for calibration. You only have to touch cover window using magnetic bar. It is quite useful for the corrective work in the explosive area.
- LCD display with back light
LCD offers real-time display of gas density and back light offers easy reading even in dark area.
- User programming
User programming calibration density and detection range offers user's own operating functions.
- Built-in HD(high dissolution) A/D converter for accurate output signal.
- Multi signal output
Various output signals - DC 4-20mA, 2 step-relay contact, & RS-485(option) – provides best networking with all kinds of devices & equipments.
- 4-20mA transmitter
4-20mA output enables stable and long distance (maximum 2.5km) signal transmission.
- RS-485
RS-485 enables stable and long distance (maximum 1.2km) signal communication.
- Alarm output
SPST 2 step relay contacts (AL1/AL2).

3> Specification

Detection principle	Catalytic, Electro-Chemical, TCD or NDIR
Built-in display	2-lines x 8-characters LCD with back light
Gas sampling	Diffusion type
Target gas	Please refer to the target gas list.
Measurement range	0 ~ 100 %LEL, 0~10,000ppm. 0~100% VOL
Response time	Within 20 sec., 90% / full scale
Accuracy	$\leq \pm 2\%$ / full scale
Sensor displacement	Zero – $\leq \pm 2\%$ LEL / 6 month, span - $\leq \pm 2\%$ LEL / 6 month
Input power	DC 20 ~ 30V
Output power	4 ~ 20mA/Full Scale - 2.5km transmission
Operating temp.& humidity	-20℃ ~ 60℃, 5 ~ 95% RH (Non-condensing)
Signal cable	CVVS & CVVSB 1.25sq x 3 wire - shield type
Wire conduit	1/2" or 3/4" PF, NPT
Installation type	Wall or Pipe Mounting
Exterior material	Cast Aluminum Alloy
Explosion-proof	Ex d IIC T5
Output	2 step- relay contact (ALARM-1/ALARM-2)
Communication output	RS-485 communication output(option)
Sensor operation period	5 years (in air)
Sensor warranty period	1 year

4> Parts & Description

1. Amp & Power Board

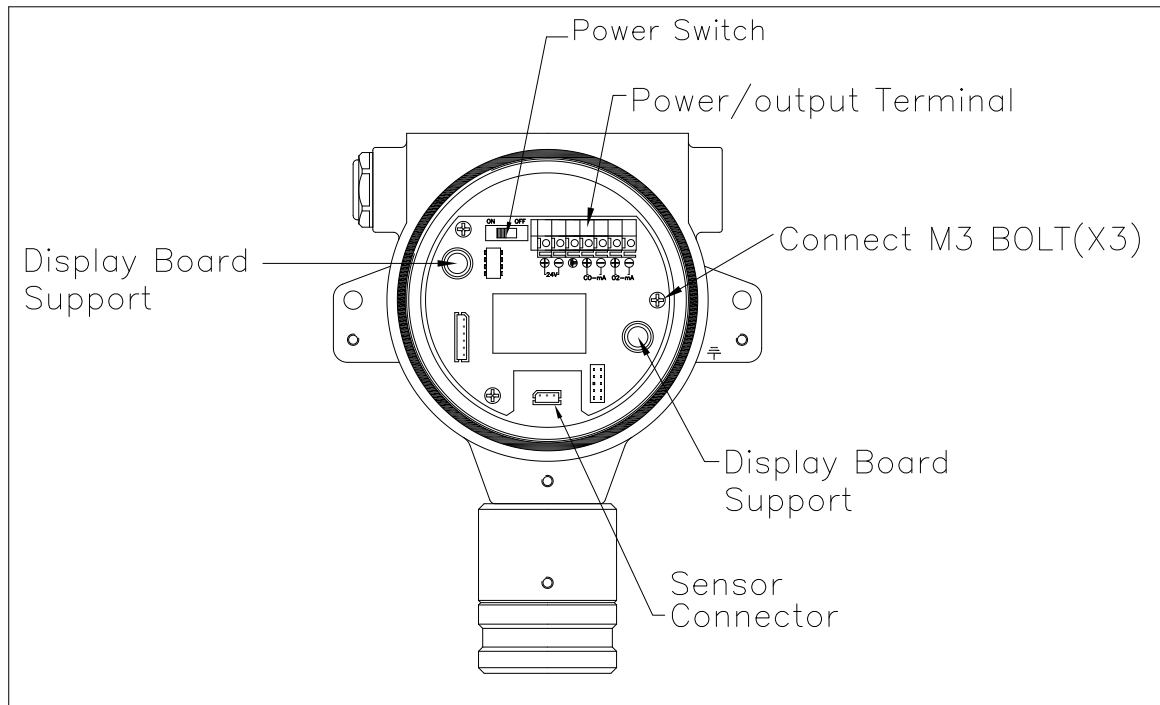

2. Transmitter Board

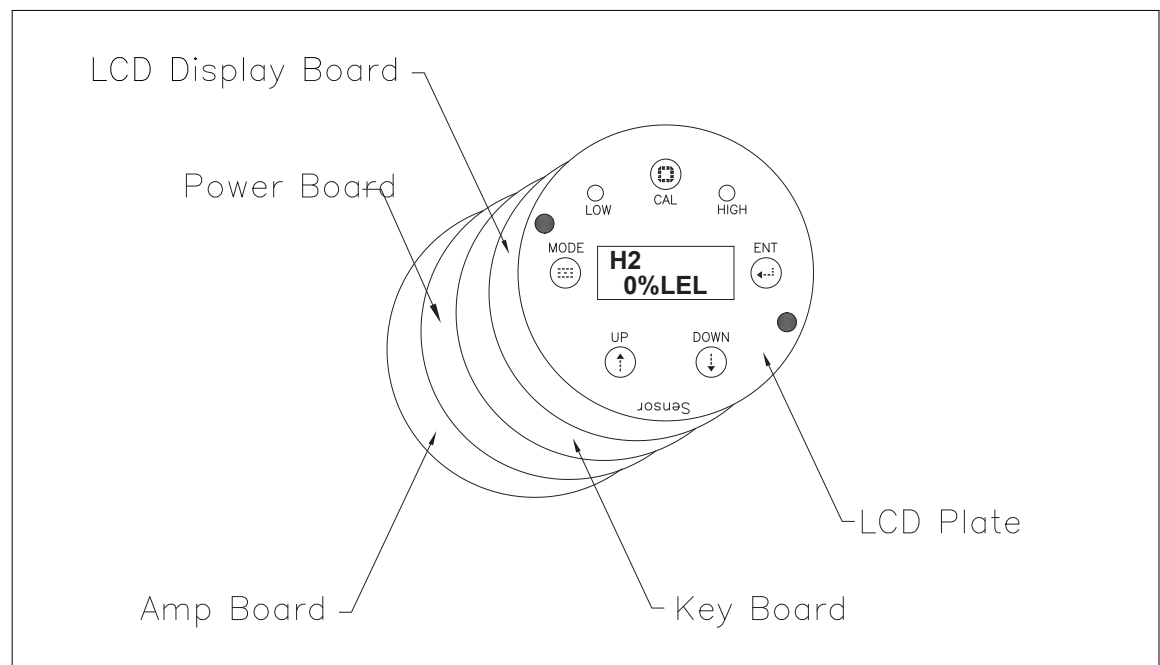

3. Parts' Name and Description

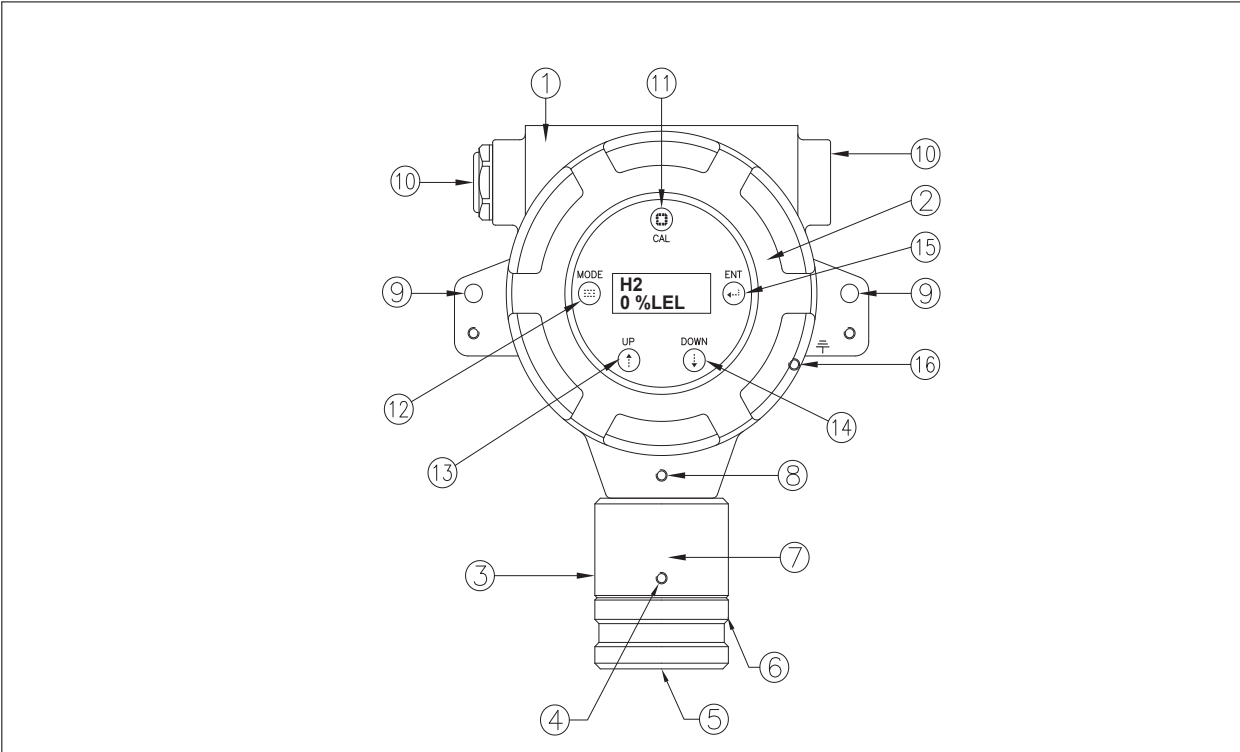

1. DETECTOR HOSING BODY	2. DETECTOR HOSING COVER
3. SENSOR HOUSING	4. M4 HEADLESS BOLT
5. CALIBRATION NIPPLE INSERT	6. SENSOR CAP
7. GAS SENSOR	8. M4 HEADLESS BOLT
9. MOUNT HOLES	10. CONDUIT CONNECTION
11. CALIBRATION KEY	12. MODE KEY
13. UP KEY	14. DOWN KEY
15. ENT KEY	16. M3 HEADLESS BOLT

5> Sensor Calibration

Please carry out calibration periodically in order to keep optimum sensor condition at least once a year.

1. Zero Calibration

Please follow below procedure:

- ① Please touch CAL key through the window of cover using magnetic bar. And then, LCD shows below:

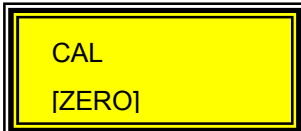

- ② Please touch ENT key through the window using magnetic bar. And then, LCD shows below:



- ③ Please infuse standard gas such as clean air or nitrogen gas for one minute.
- ④ When the measured value becomes stable, please touch ENT key using magnetic bar.
- ⑤ When the zero calibration finishes, [OK] will be shown on LCD:



▲ Caution: Zero calibration should be processed with clean air or 99% nitrogen gas. (For O₂ gas, you must use nitrogen gas 99.8% or more.)

2. Span Calibration

Please follow below procedure:

- ① Please fix the calibration nipple on the sensor cap.



Calibration nipple

- ② Please touch CAL key through the window of cover using magnetic bar.
- ③ Please touch MODE key through the window using magnetic bar to move into CAL menu. And

then, LCD shows below:



- ④ Please touch ENT key through the window using magnetic bar. And then, LCD shows below:

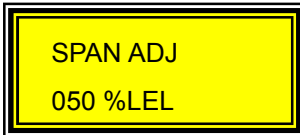

- ⑤ Please touch UP & DOWN key through the window to input the calibration gas density. And then, please touch ENT key to confirm it. And then, LCD shows below:

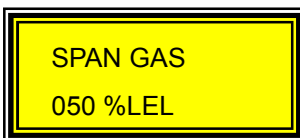

Density of calibration gas

- ⑥ Please infuse the standard gas for one minute until the density value becomes stable. And then, please touch ENT key.
- ⑦ Please stop calibration gas and remove the calibration nipple. And then, LCD shows below as gas density value goes down.

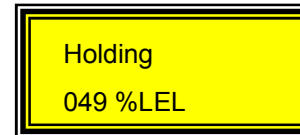

- ⑧ When the density value goes down 10%LEL or below, measuring mode starts automatically.

▲ **Caution:** The standard gas should be within the designated density range. If you use it out of the designated density range, the calibration is not possible and the sensor may be damaged or lifetime may be reduced extremely. (Default: gas density = 50%LEL & measuring range 0 ~ 100%LEL)

▲ **Caution:** Please start calibration after 4 minutes from power on after sensor replacement.

6> Sensor Replacement

Please follow below procedure:

- ① Please turn off the power.
- ② Please open the front cover.
- ③ Please disassemble the display board.
- ④ Please disassemble the three line connector between sensor and sensor board.
- ⑤ Please pull out the headless bolt to disassemble the sensor cap.
- ⑥ Please assemble new sensor cap and tighten the headless bolt.
- ⑦ Please assemble three line connector between sensor and sensor board.
- ⑧ Please push and insert the guide bar into the bushing of power board accurately to fix the display board.
- ⑨ Please assemble the front cover.
- ⑩ Please turn on the power.
- ⑪ Please proceed with sensor calibration.

▲ Caution

- ✓ **Before replacing sensor, please make sure that power should be off.**
- ✓ **Please make sure whether the direction of connector's socket is correct.**
- ✓ **Please fully tighten the sensor cap and front cover to secure water proof.**

6> Wiring

1. Terminals

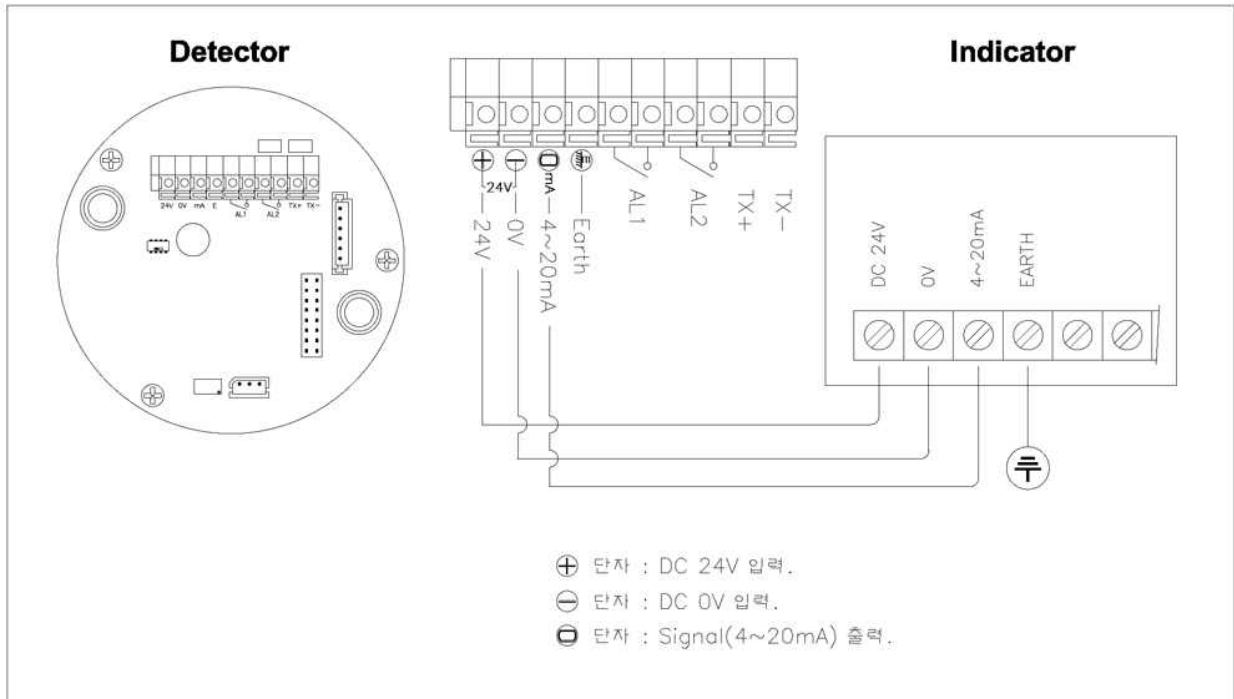

2. Cable Specification

1] Cable Type: Shield Cable

2] Transmission distance and required cable specification

Transmission distance	0 ~ 500m	501 ~ 1,500m	Over 1,500m
Required cable specification	0.75sq	1.25sq	2.0sq

7> Installation

1. Front view

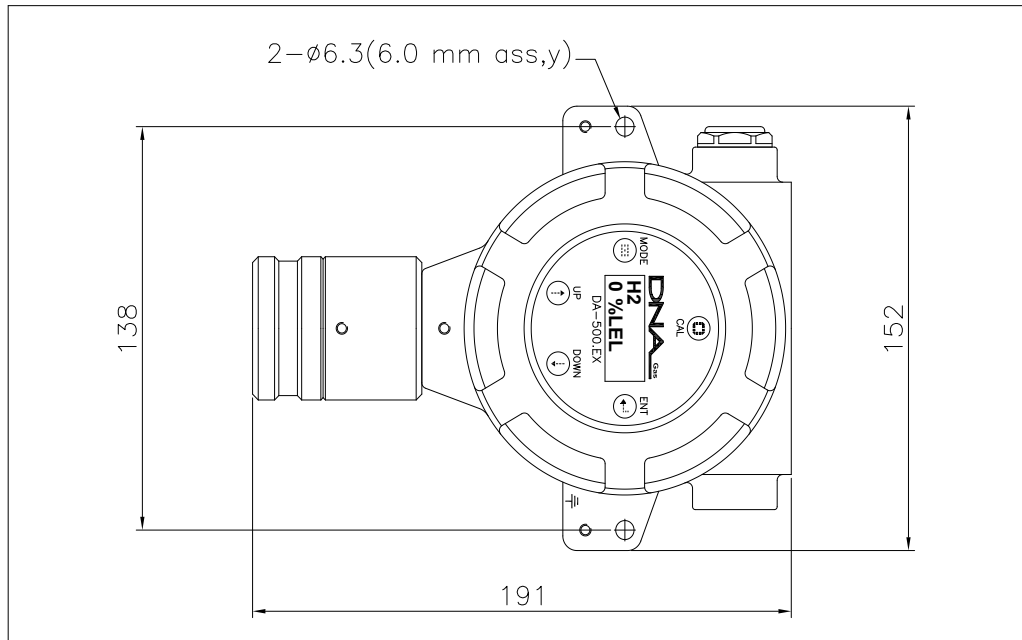

2. Side view

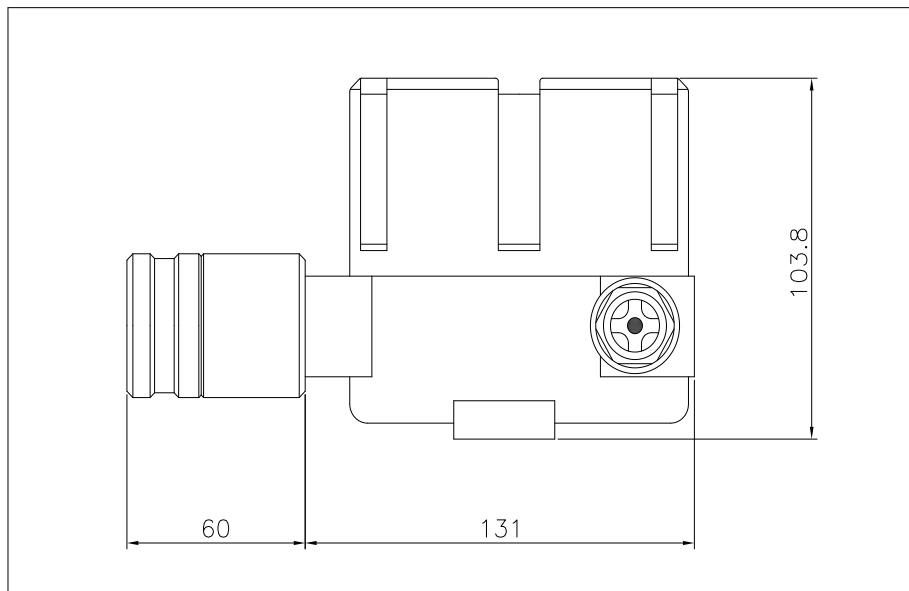

3. Cable conduit and installation position

- Cable Conduit: 1/2', 3/4" PF/NPT.
- In open area, please install JDA-500 as close as possible to the potential gas leakage place such as gas valve and pipe connection.
- In closed area,
 - ▷ Light gas (specific gravity < 1): Please install JDA-500 20 ~ 30cm from ceiling.
 - ▷ Heavy gas (specific gravity > 1): Please install JDA-500 20 ~ 30cm from the floor.

4. Cautions

- Please avoid any potential electrical troubles such as rain drops.
- Please avoid any vibration or physical impact which can affect the output signal value.
- Please avoid high temperature or humidity.
- Please avoid any electrical noise such as motor, pump, or high voltage power line.
- Please choose the place where you can do repair & maintenance job easily. If it is not available, we recommend suction type detectors.

8> Setting Menu

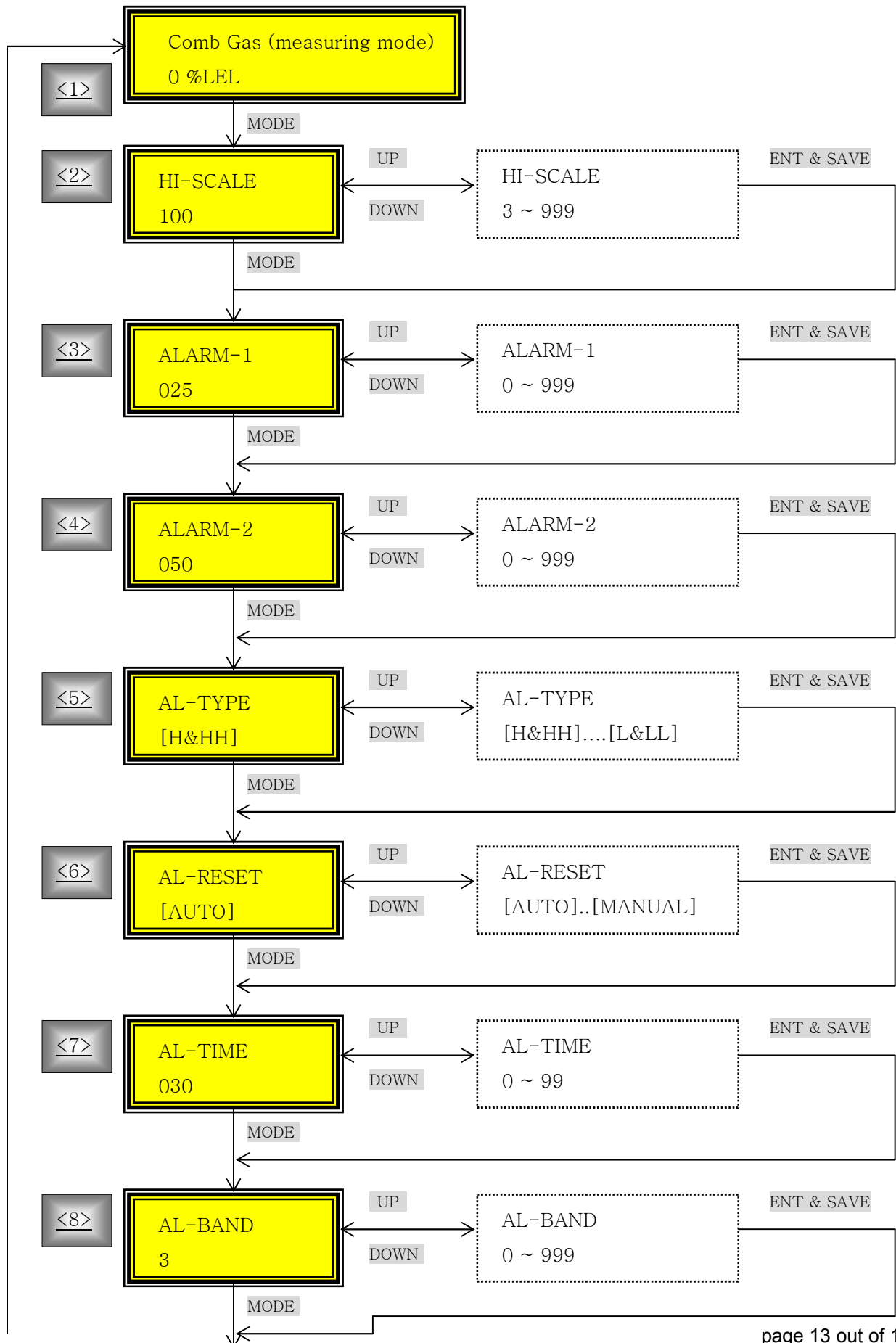

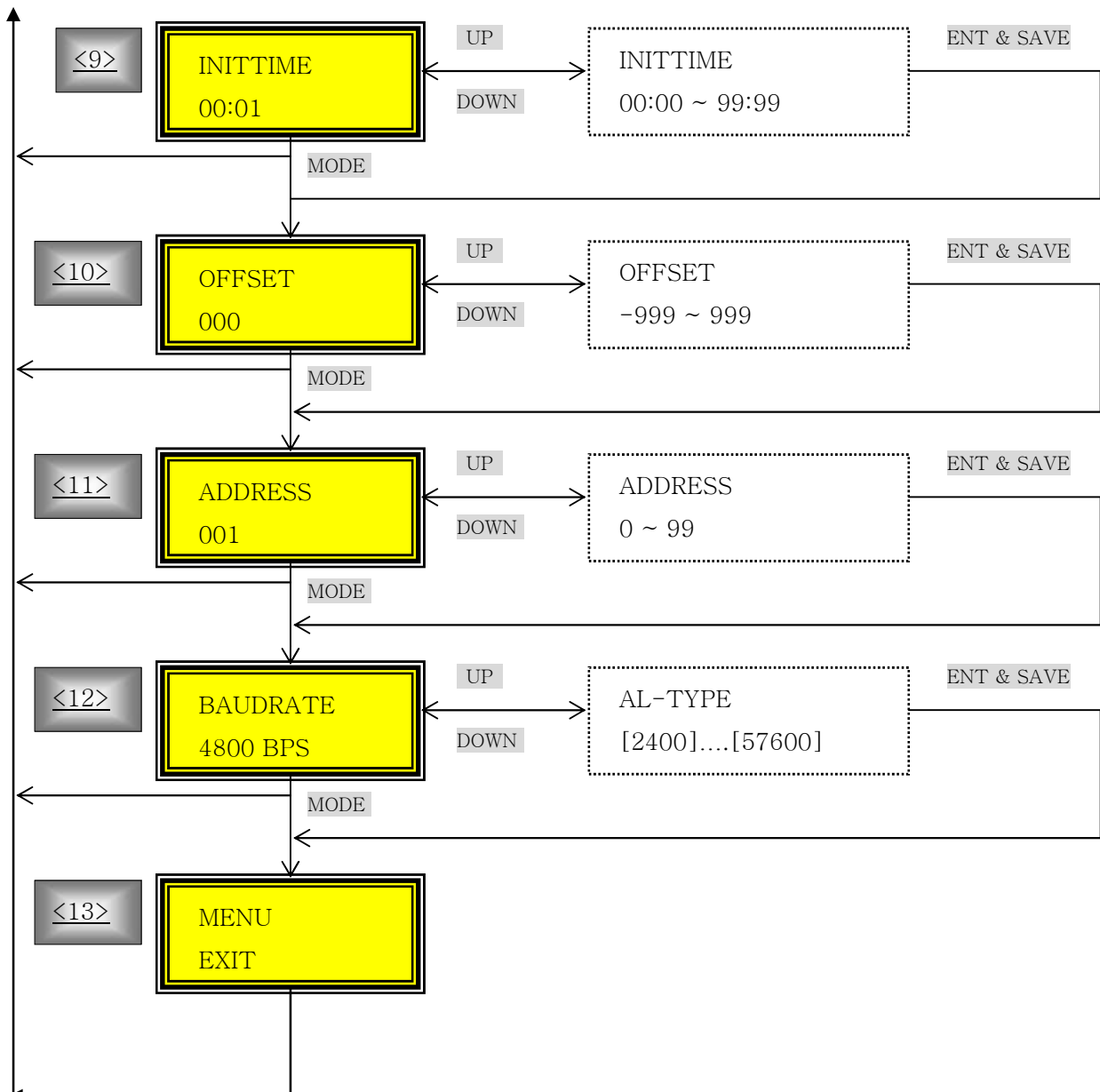

<1> Measuring mode

Please push MODE key for 2 seconds to start setting mode.

<2> HI-SCALE

Set 4 ~ 20mA output signal for full scale.

(ex) If you set SCALE to 100, 4mA output signal displays '0' and 20mA output signal displays '100'.

<3> ALARM-1

According to 'AL TYPE', alarm #1 on.

<4> ALARM-2

According to 'AL TYPE', alarm #2 on.

<5> AL-TYPE(ALARM-TYPE)

It has four(4) alarm types: L&L, L&H, H&L, and H&H

You can use two alarm relay – relay 1 & relay 2.

(ex) If you set 'AL TYPE' to H&L:

→ Relay 1 set high: when the measured value is higher than set value, alarm on.

→ Relay 2 set low: when the measured value is lower than set value, alarm on.

<6> AL-RESET(ALARM RESET)

Select release method on alarm relay contact or buzzer.

Select 'AUTO' ↔ 'MANUAL'

<1> AUTO: The relay contact & LED releases according to set value automatically.

<2> MANUAL: Only when you press reset switch, the relay contact & LED releases.

<7> AL-TIME(Alarm delay time)

This function is to prevent the normal operation of sensor against any momentary malfunctions affected by outside impact or noise.

(ex) When alarm value sets '50' & 'AL TIME' sets '5'.

→ Only when the measured value keeps higher than alarm set value during longer than '5' seconds, alarm on.

<8> AL-BAND(Alarm dead band)

Relay output usually repeats on/off around the alarm set value and it makes trouble. 'D-BAND' function gives hysteresis value on the alarm set value to remove this kind of trouble.

(ex1) If 'ALARM 1' sets 20 & 'ALRAM 2' sets 50, 'ALARM TYPE' sets 'H&H' & 'AL-BAND' sets '3'

→ When value displays higher than 20 and 50, alarm on ↔ lower than 17

(ex2) If 'ALARM 1' sets 20 & 'ALRAM 2' sets 50,, 'ALARM TYPE' sets 'L&H' & 'AL-BAND' sets '3'

→ When value displays lower than '20' and higher than 50, alarm on ↔ higher than '23', alarm off

<9> INITTIME(Initialization time)

After certain time from power on, sensor can provide stable output.

<10> OFFSET(correction for measured value)

Compensate the measured value.

(ex) OFFSET: If it sets '+5',

→ When the measured value is '-5', it displays '0' after compensation of '+5'.

<11> ADDRESS

- Set RS-485 address.(0 ~ 99)

<12> BAUDRATE

- Set RS-485 baud rate.

9> Sensor Calibration Menu

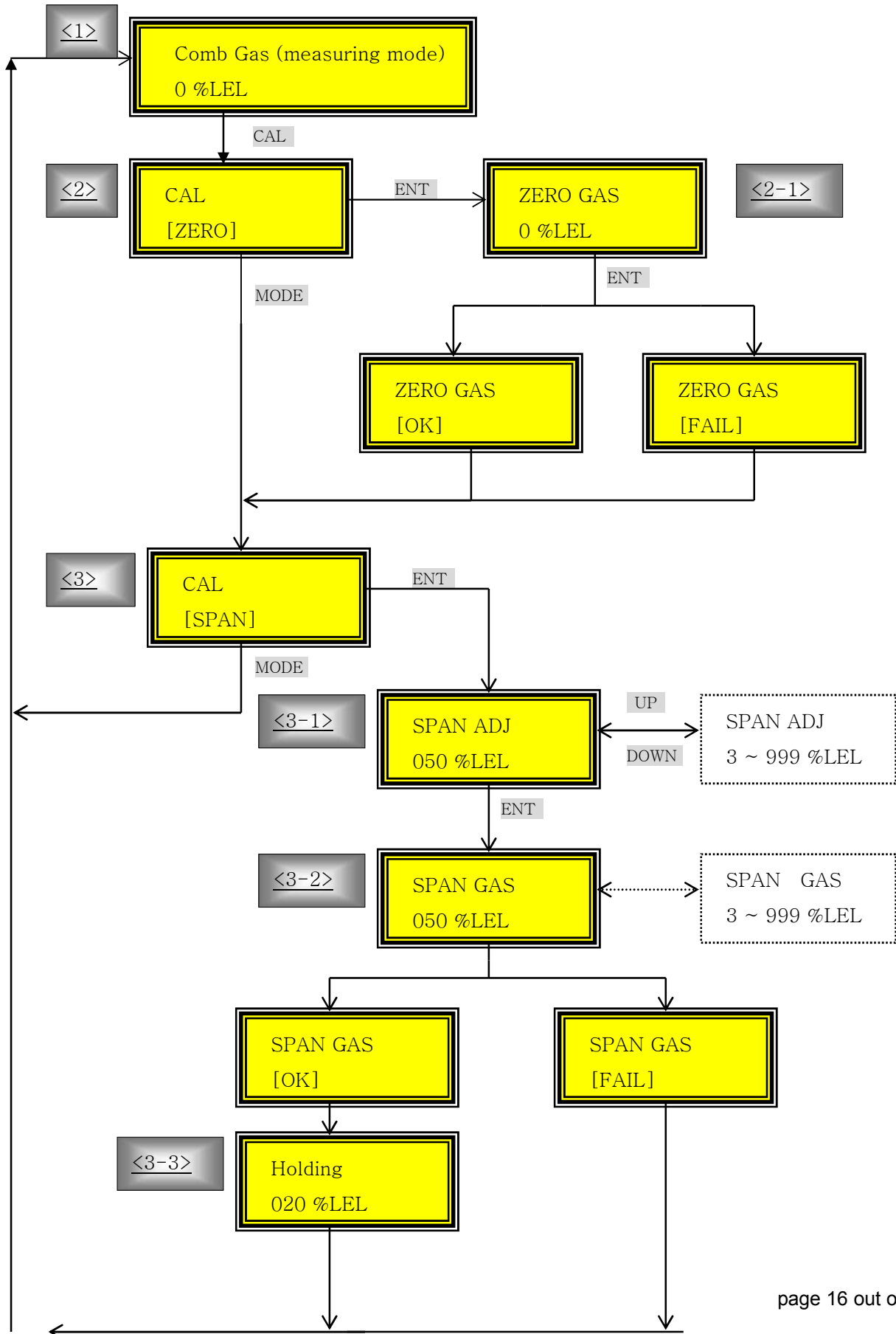

<1> Calibration mode

Please touch CAL key on the window using magnetic bar to start calibration mode.

<2> Zero calibration

At 'CAL [ZERO]', please touch ENT key on the window using magnetic bar. When 'ZERO GAS <0.0 %LEL>' shows on LCD, please infuse clean air or 100% nitrogen gas until the measured value becomes stable. And then, please touch ENT key on the window to confirm it. If the zero calibration is successful, 'ZERO GAS [OK]' will be displayed. If calibration is not successful, "ZERO GAS [FAIL]" will be displayed during 2 seconds.

<3> SPAN CALIBRATION

(ex) Target gas: H2

Standard gas : H2(50 %LEL)+Air Balance

- (1) At the CAL [SPAN], please touch the ENT key on the window using magnetic bar.
- (2) Please input the density value of standard H2 gas, 50%LEL, using UP and DOWN key on the window using magnetic bar. And then, please touch ENT key to confirm it. LCD shows below:

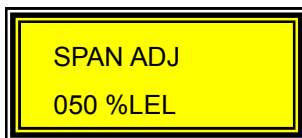

- (2) Please infuse the standard H2 gas until the displayed value becomes stable as LCD shows below picture. And please touch ENT key to confirm it.

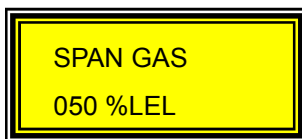

- (3) If the SPAN calibration is successful, LCD shows below:

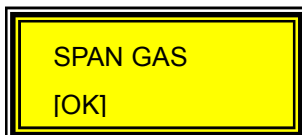

- (4) Measuring mode will start automatically when the density value goes down under 10%LEL.

