



QMS
ISO 9001:2000
登録番号 JSAQ 097



JAB
QMS Accreditation
認定番号R001



DIGITAL CONTROLLER TTX-700



TOHO ELECTRONICS INC.

DIGITAL CONTROLLER TTX-700

DIN rail installation type, 2 channels digital temperature controller
 Feasible to operate the various settings from the front display and key switches
 Communications can be connected up to 31 units

Features

Self-Tuning PID

Most appropriate PID constant is automatically reckoned up for control objects. PID constant is calculated when making alteration of setting value, or it is corrected when occurring disturbance/hunting etc.

Blind Function

At the request, desirable parameter screen is only displayed and set up.

Simplified Timer

ON/OFF setting control is available after some certain interval. Function of ON/OFF alarm output is independently usable.

Multiple Inputs

Thermocouple/R.T.D.(Pt 100 & JPt 100) are selectable by front key.

Sampling Cycle Time

0.25 sec of sampling time is adapted.

Manual Control (Balanceless & Bumpless)

Manual output function is applicable for versatile applications of instrumentation systems.

Communication Function (RS-485·MODBUS)

The communication distance is extended up to 500 meters, and maximum 31 units can be connected with the computer at a time. Centralized supervision is available for collection of the whole data and alteration of setting values at remote location. In addition to conventional TTM series protocol, a protocol corresponds to MODBUS protocol.

Digital PV Filter

For abrupt alteration of input value, filter effect is operational on software.

PID Over-Shoot Protection

It is functional to inhibit PID Over-Shoot.

DI Functions (CH1 only, CH2 only, or CH1+CH2 both)

The following functions are selective.

- ①SV/SV2
- ②RUN/READY
- ③Auto/Manual
- ④Normal/Reverse Action
- ⑤AT Start/Stop
- ⑥Normal(SV2)/Reverse(SV2) Action
- ⑦Timer Start/Reset

Others

- ①CT Input (Input Monitor usable)
- ②Shift setting of OFF position during ON/OFF control (for both output 1 & 2)
- ③Heating/Cooling control (PID control function equipped at cooling side)

Front Panel

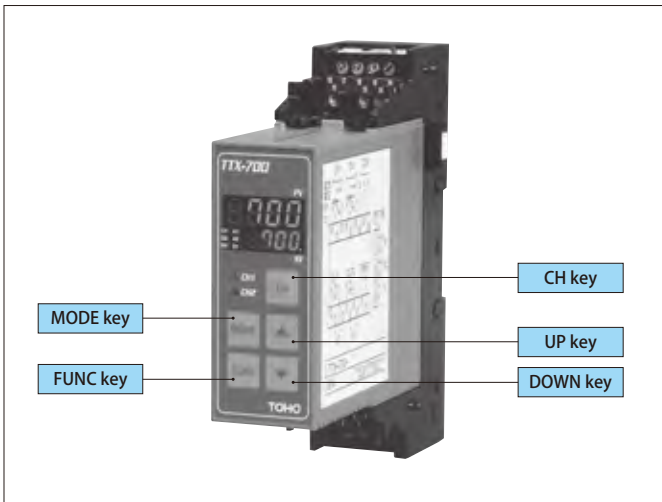

MODE	MODE key ● Mode key for shifting display (Memorizes the setting parameters)
FUNC	FUNC key ● Executes a set function ① Digit shift key (Selected digit is blinking): Effective in all modes ② AT Start/Stop : Function is switched by each press, only effective in operation mode ③ RUN/READY : Function is switched by each press, only effective in operation mode ④ Timer Start/Reset : Function is switched by each press, only effective in operation mode
▼	● Use when decreasing setting values Push 1s to 10s : 1 digit/100ms Push 10s to 20s : 10 digits/100ms Push 20s or over : 100 digits/100ms
▲	● Use when increasing setting values Push 1s to 10s : 1 digit/100ms Push 10s to 20s : 10 digits/100ms Push 20s or over : 100 digits/100ms
CH	CH key ● Changes display or setting channels over CH1 and CH2 are switched by each press

Operation Flow

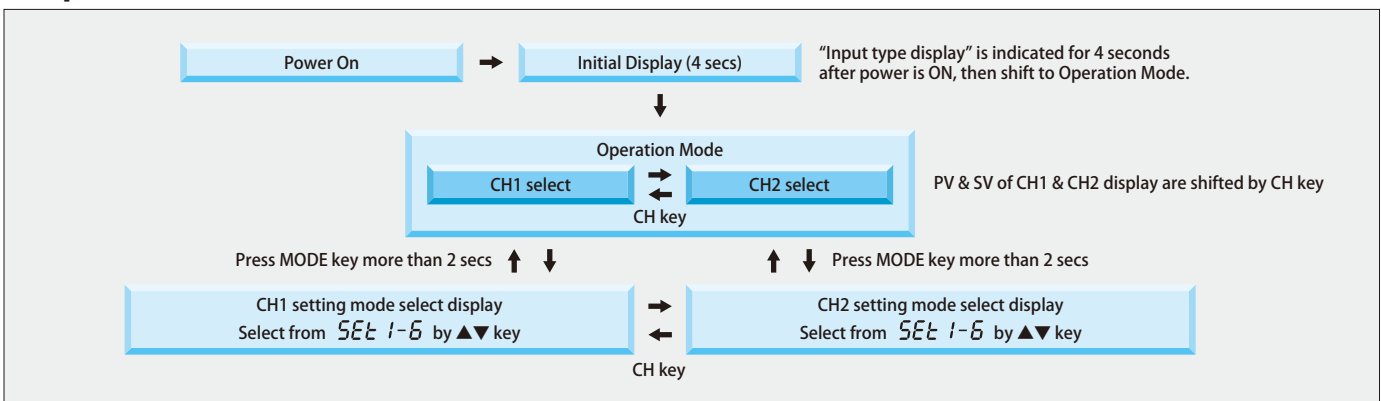

Advanced Features

Self-Tuning PID

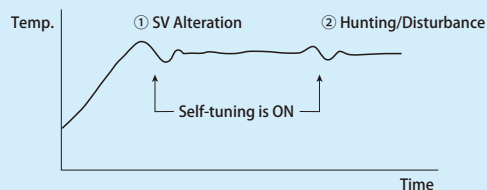

Blind Function

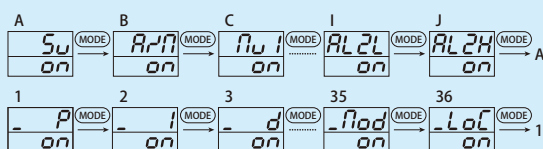

The mode screen or the parameter screen whichever you demand can be displayed by merely pressing a key, at the request. When the SV screen is erased, the set value is normally not indicated but the measured value (PV) is only shown.

Timer Function

1. Bread Oven Machine

- Put dough into oven and press the timer start key.
- While setting timer, temperature in oven is controlled by heater.
- After timer counts up, control of oven is stopped automatically. (This example is for control stop after the timer counts up.)

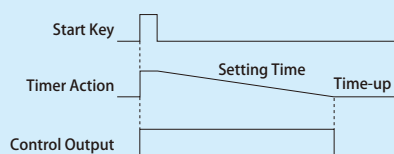

2. Package Machine and Industry Machinery

(In case of start of control after the relative equipments are prepared)

- When power is "ON", the timer starts to count.
- While setting timer, control output is stopped.
- After the timer counts up, control is started automatically. (For control start after the timer counts up.)

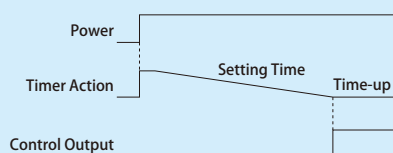

Automatic/Manual Control

Automatic/Manual control can be switched by front key for DI or communication. When checking the manipulation action for valve and heater during a system test run, or when normal control is not operational due to sensor failure, the system can be operated manually in this mode.

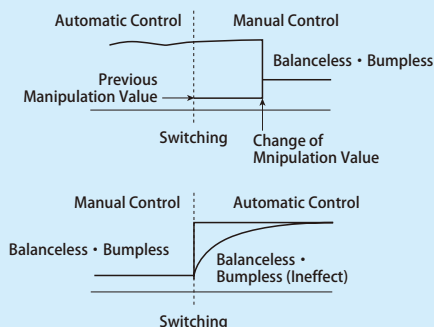

Communication Function

Connection to Personal Computer TTX-700 controllers can observe concentrically by personal computer, as connection diagram instructed below.

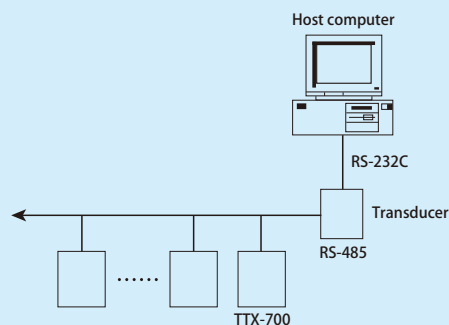

Digital PV Filter

This is a function to realize a CR filter effect on software by means of primary delay arithmetic on the measured value (PV).

The filter effect can be set by time constant (t).

(The time constant is a period to reach 63% of PV value, when the input changes stepwise.)

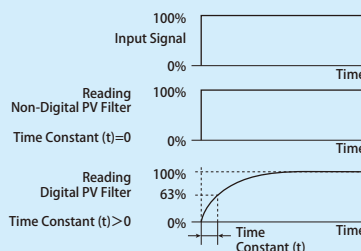

Digital PV filter with the following uses

- To eliminate high frequency noise : When electric noise is added to the input, the adverse effect is reduced.
- When input changes abruptly, the response delay is possibly made.

PID Over-Shoot Protection

It is functional to inhibit PID Over-Shoot.

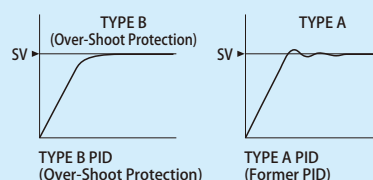

Shifting OFF Position in ON-OFF Control

When the Shift value is set to 0 (zero), the OFF position is the set value position.

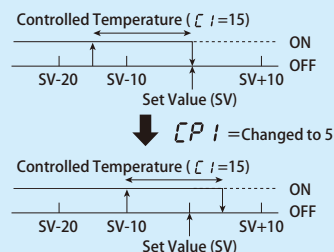

When the OFF position setting is shifted by +5, ON/OFF position shifts to that of +5 minutes upper than the original position, though the set value is not changed. When the OFF position setting is shifted toward the minus direction, the OFF position shifts in the reverse direction.

Heating/Cooling PID Control

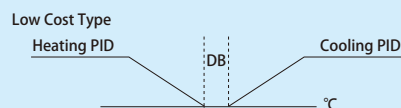

Standard Specifications

Input Switchable	Thermocouple	K, J, R, T, N, S, B (JIS C 1602-1995)	
	R.T.D.	Pt100, JPt100 (Load resistance : 10Ω or less) (JIS C 1604-1997)	
	Current	4 to 20mA DC (Input resistance 250Ω)	
	Voltage	1 to 5V DC, 0-5V DC, 0 to 10V DC (Input resistance 500kΩ or more), 0 to 10mV DC (input resistance 1MΩ or more)	
Display	PV display	7 segments Green LED 7.6mm height	
	SV display	7 segments Red LED 5.3mm height	
	Lamp	CH1/CH2 select lamp (Green), CH1/CH2 output lamp (Red), CH1/CH2 event lamp (Red), COM lamp (1st decimal digit of SV)	
Control Method	PID (Type A, Type B) Auto-Tuning Self-Tuning	Proportional band (P1)	0.1 to 200.0% of setting limiter span
		Proportional band (P2)	0.10 to 10.00 times (Magnificaiton to P)
		Integral time (I)	1 to 3600 sec (0 : OFF)
		Derivative time (D)	1 to 3600 sec (0 : OFF)
		Proportional cycle (T1, T2)	1 to 120 sec
		Dead band (DB)	-100.0 to +100.0 or -100 to +100 (°C)
	ON/OFF	Control sensitivity (C1, C2)	0 to 999 or 0.0 to 999.9 (°C)
OFF point of OUT 1 & 2	Position of setting	-199 to 999 or -199.9 to 999.9 (°C)	
Control Output	Relay Contact	250V AC, 3A (Load resistance) 1a contact	
	SSR Drive Voltage	0 to 12V DC (Load resistance : 600Ω or more)	
	Current	4 to 20mA DC (Load resistance : 600Ω or less)	
	Voltage	1 to 5V DC (Load resistance : 1kΩ or more)	
Sampling Time	0.25 sec (Output change period is the same)		
Setting and Indication Accuracy	Thermocouple/R.T.D. /Current•Voltage	Refer to the table of Input and scale range	
Memory Element	EEPROM		
Voltage Source	24V DC ±10%		
Weight	Less than 200g		
Power Consumption	Less than 4W		
Accessories	Instruction manual		
Standard Condition	23°C ±10°C, 45 to 75%RH		
Operating Condition	0 to 50°C, 20 to 90%RH (under non-condensation)		
Storage Condition	-25 to 70°C, 5 to 95%RH (under non-condensation)		
Functions	Manipurated Variable Limiter (ML1, MH1, ML2, MH2)	0.0 (-10.0 : Current•Voltage) to 100.0 (110.0 : Current•Voltage) %	
	Setting Limiter (SLL, SLH)	SV low limit setting range-SV high limit setting range, but the difference more than 50 digits is required between low and high range	
	Selectable Control Mode (CNT)	PID type (Normal, Reverse), ON/OFF (Normal, Reverse)	
	PV Correction 0 Point Setting (PVS)	-199 to 999 or -199.9 to 999.9	
	PV Correction Gain Setting (PVG)	0.50 to 2.00 (times)	
	Input Filter	0 to 99 (sec)	
	Blind Function	No indication available for non-required display by front key.	
	CT Input	Setting range : 1 to 30A, Accuracy : ±5% (Setting resolution 1A)	
	Timer Operation Mode	0.00 minute to 59.59 minutes, 0.00 hour to 99.59 hours: Accuracy : ±(1.5% + 0.5 sec) of setting time.	
	Watch Dog Function	EEPROM data check (Err0), A/D converter check (Err1), Auto-Tuning check (Err2)	
	Heating & Cooling	Only input of ch 1 is available when heating/cooling action	
	Communication	RS-485 conformable : Multi-Drop 2 line system. Max. 1:31 stations Protocol : TOHO TTM-100 type MODOBUS (RTU/ASC II) Communication speed : 1200/2400/4800/9600/19200bps	
	Other function	Manual Control, Auto-Tuning (AT) Coefficient	

Additional Functions (option)

Event	Function : PV contact output (8 modes), Special contact output (3 modes), additional functions (3 modes) Setting Range : -199.9 to 999.9 or -1999 to 9999 (°C) Sensitivity : 0.0 to 999.9 or 0 to 9999 (°C) Rating : 250V AC 1A (Load resistance) 1a contact Contact polarity is selectable either normal open or close.
DI	Function : SV/SV2 switchable (OFF : SV2), Auto/Manual switchable (OFF : Manual), Run/Ready switchable, Normal/Reverse switchable, Normal (SV2)/Reverse (SV) switchable, Timer Start/Reset Input Specifications : Minimum input time : 250ms, OFF voltage : 6V DC max, ON current : 6mA max, Permissible resistance value between terminals : ON=333Ω max, OFF=500kΩ min

Wiring

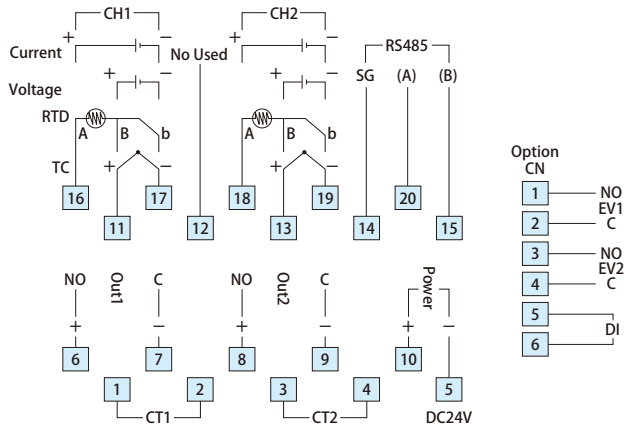

Terminals

Relay Output	C : Common. NO : Normal open
DI	No parity
Communication	Connect T/R (A) and T/R (B)
SG	Use as communication signal ground
SSR Drive Output	Connect directly to + & - input of SSR
CT	Connect specific current transformer (CTL)
R.T.D. Input	Connect to A, B and b with care
Thermocouple Input	Connect to polarity (+, -) with care
Output	Connect to polarity (+, -) with care
Current, Voltage Output	Connect to polarity (+, -) with care

Input and Range (Thermocouple & R.T.D. switchable by key)

Thermocouple	Setting Range		Display Range		Measurement Accuracy		
	Non-decimal point	Decimal point	Non-decimal point	Decimal point			
K	°C -200 to 1370	_____	-210 to 1380	_____	±(0.3% + 1 digit) of input value or ±2°C, either of bigger numeral values is taken. -100 to 0°C : ±3°C, -200 to 100°C : ±4°C Thermocouple B under 400°C is not regulated.		
J	°C -200 to 850	_____	-210 to 860	_____			
R	°C 0 to 1700	_____	-10 to 1710	_____			
T	°C -200 to 400	_____	-210 to 410	_____			
N	°C -200 to 1300	_____	-210 to 1310	_____			
S	°C 0 to 1700	_____	-10 to 1710	_____			
B	°C 0 to 1800	_____	-20 to 1802	_____			
R.T.D.	Setting Range		Display Range		Measurement Accuracy		
	Non-decimal point	Decimal point	Non-decimal point	Decimal point			
Pt100Ω	°C -190 to 500	-190.0 to 500.0	-199 to 530	-199.9 to 530.0	±(0.3% + 1 digit) of input value or ±0.9°C, either of bigger numeral values is taken.		
JPt100Ω	°C -190 to 500	-190.0 to 500.0	-199 to 520	-199.9 to 520.0			
Current, Voltage	Setting Range		Display Range		Measurement Accuracy		
	Non-decimal point	Decimal point	Non-decimal point	Decimal point			
	0 to 5V DC	V	-1999 to +9999 Decimial point is switchable	-1999 to +9999		Decimial point is switchable	±(0.3% + 1 digit) in setting limiter span.
	1 to 5V DC	V					
	0 to 10V DC	V					
0 to 10mV DC	mV						
4 to 20mA DC	mA						

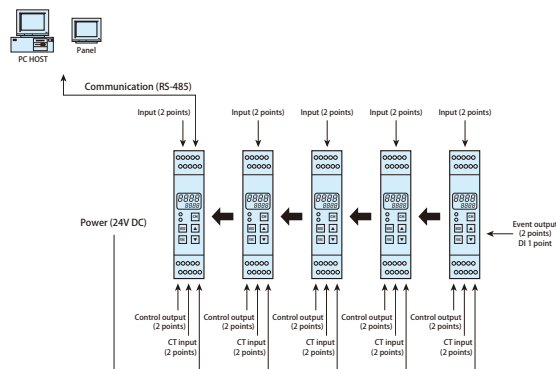

Connection

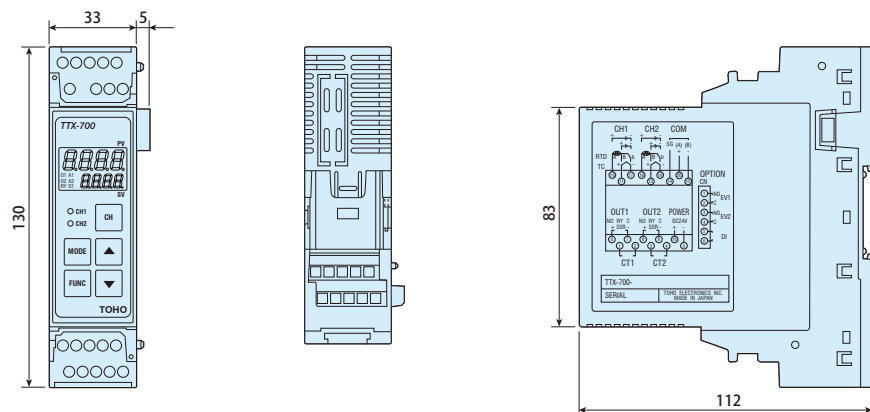

Dimensions

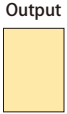

■ Ordering Information (Model Configurations)

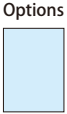
TTX-700-  -   - 

Input		Thermocouple, R.T.D., 0 to 10mA DC
	2	4 to 20mA DC, 0 to 5V DC, 1 to 5V DC
Out 1 Out 2	R	Relay contact
	P	SSR drive voltage 12V DC
	I	Current 4 to 20mA DC
	V	Voltage 1 to 5V DC
Options	A	Event Output
	E	DI

Please refer to this table for appropriate specifications when placing order.