





# Operation Specifications

Model: TTM-339  
 Designation: Program Controller  
 Job number: K188

Customer confirmation stamp		
Sales	Person responsible	Originator

We have prepared a set of product specifications.  
 Please confirm it and return one of the copies to us by

Date:

APPROVED	APPROVED	CHECKED	DESIGNED	DATE Nov. 26, 2009	Job. No. K188	TITLE Program Controller Operation Specifications	
				MODEL TTM-339		DWG No. 48-7000-F	PAGE 1/72
<b>TOHO ELECTRONICS INC.</b>							

	DWG No. 48-7000-F	PAGE 2/72
--	----------------------	--------------

## Contents

1.	Scope of Application .....	3
2.	Outline .....	3
3.	Display/key .....	3
4.	Flow of Mode Change Operation and Run Operation .....	6
5.	Mode Description .....	7
6.	List of Setting Values .....	25
7.	Screen Existence/Nonexistence Conditions .....	37
8.	Regarding Various Functions .....	43
9.	Communications .....	56
10.	Blind Function .....	68
11.	Electric Power Outage Function .....	70
12.	Error Names, Display, and Occurrence Conditions/Release Method .....	71
13.	Model .....	72

	DWG No. 48-7000-F	PAGE 3/72
--	----------------------	--------------

### 1. Scope of Application

These Operation specifications apply to the standard program controller, TTM-339, supplied by TOHO ELECTRONICS INC.

### 2. Outline

This product is a 96-mm square type LCD display program controller capable of handling up to 15 patterns /99 steps.

The number of a temperature input is 1; the type of input is a multi-input composed of thermocouple, resistance temperature detector, voltage and current.

Either relay contact output, SSR drive voltage output or current 4-to-20-mA output is selected for the primary control output, and either relay contact output, SSR output, current 4-to-20-mA output or none can be selected for another output of the primary control output.

Other inputs/outputs are available: no-voltage contact input, relay, open collector output and communications RS-485.

In addition, existence/nonexistence of input/output is selectable, depending on models.

### 3. Display/key

#### 3.1 Full panel face

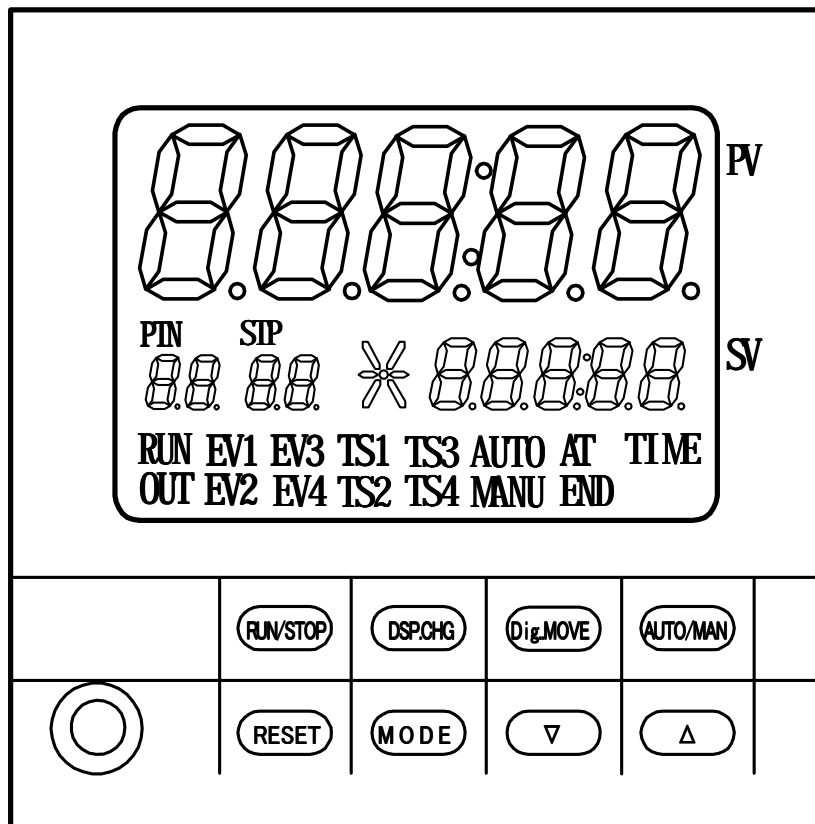

### 3.2 Segment display section

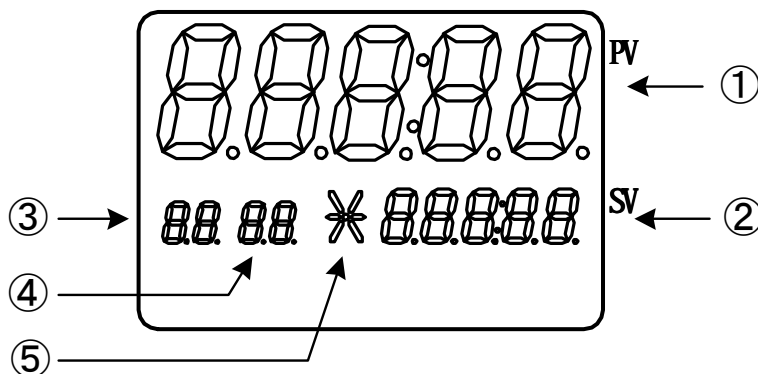

No.	Segment character	Content
	PV (5 digits in the upper row)	Displays PV, etc.
	SV (5 digits in the lower row)	Displays SV, etc. Fixed to 0 during a stop. Displays "TIME" during a timer run.
	Pattern digit (2 digits in the lower row left)	Displays the pattern No., etc. presently in selection.
	Step digit (2 digits in the lower row right)	In a stop: Displays the number of steps of the pattern presently in selection. In a run: Displays the step No., etc. presently in progress.
	Operating status (lower row center; 6 segments)	Indicates the program operating status.

### 3.3 Lamp display section

No.	Lamp character	Content
	PTN	Lights up while a pattern in display.
	STP	Lights up while a step in display.
	RUN	Lights up during a program run.
	OUT	Lights up at the heating output ON.
	EV1	Lights up at occurrence of Event 1.
	EV2	Lights up at occurrence of Event 2.
	EV3	Lights up at occurrence of Event 3.
	EV4	Lights up at occurrence of Event 4.
	TS1	Lights up at Time Signal 1 ON.
	TS2	Lights up at Time Signal 2 ON.
	TS3	Lights up at Time Signal 3 ON.
	TS4	Lights up at Time Signal 4 ON.
	AUTO	Lights up during an automatic run.
	MANU	Lights up during a manual run.
	AT	Lights up during an auto-tuning.
	END	Lights up at the output ON while End Signal in use.
	TIME	Lights up at the time being set.

	DWG No. 48-7000-F	PAGE 5/72
--	----------------------	--------------

### 3.4 Key

No.	Name	Content
	RUN/STOP key	Used for run start/stop, temporary stop, etc.
	DSP.CHG key	Used for display switchover, etc.
	Dig.MOVE key	Shifts the set digit leftward during setting.
	AUTO/MAN key	Switches over MANU/AUTO.
	RESET key	Used for screen return, etc.
	MODE key	Used for changing a setting item, etc.
	▽ key	Used for decreasing a numerical value, etc.
	△ key	Used for increasing a numerical value, etc.

	DWG No. 48-7000-F	PAGE 6/72
--	----------------------	--------------

### 4. Flow of Mode Change Operation and Run Operation

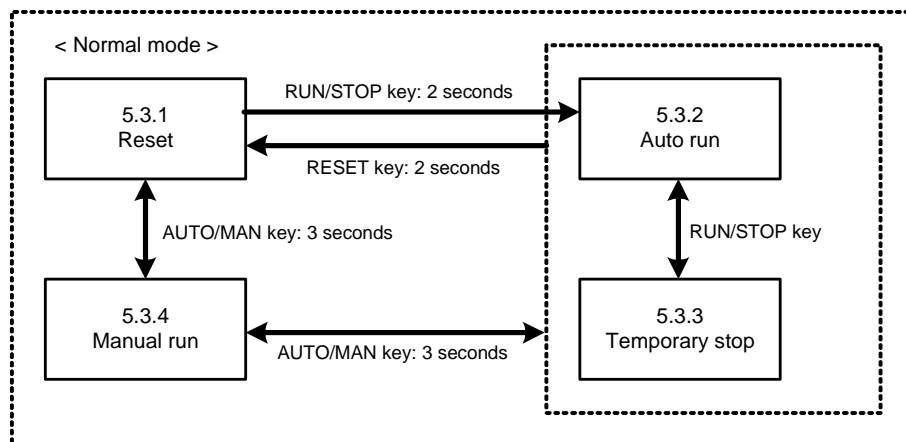
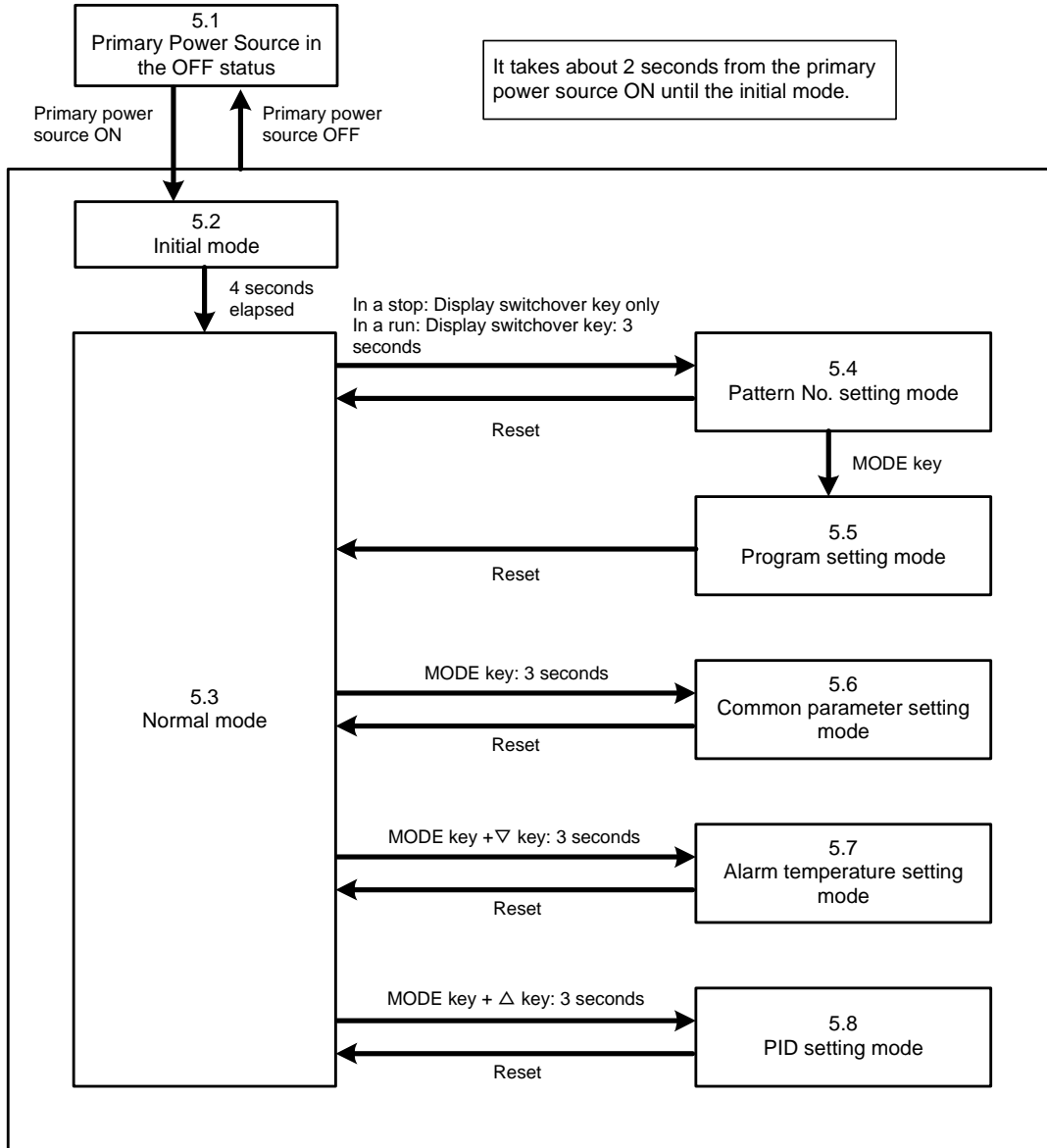

	DWG No. 48-7000-F	PAGE 7/72
--	----------------------	--------------

## 5. Mode Description

### 5.1 Primary Power Source in the OFF status

- None is displayed in the primary power source in the OFF status.
- Upon the primary power source turning to ON, the power is turned on and the mode changes to the initial mode described in Section 5.2.
- Upon the primary power source turning to OFF on another screen, the screen changes to this one.

- List of key operations

Name	Content
RUN/STOP key	NA
DSP.CHG key	NA
Dig.MOVE key	NA
AUTO/MAN key	NA
RESET key	NA
MODE key	NA
▽ key	NA
△ key	NA

- Base screen



Segment	Content
All go off.	

Lamp	Content
All go off.	

	DWG No. 48-7000-F	PAGE 8/72
--	----------------------	--------------

### 5.2 Initial mode

- Upon power turn-on with the primary power source in the OFF status, the mode screen changes to this one.
- No key operation is effective.
- Display content changes every 2 seconds in the following sequence.
  - 1) Input type
  - 2) Maximum value within the display range (with the temperature input in selection) or the upper limit of scaling (with the analog input in selection)
- Upon termination of the above display, the mode changes to the normal mode described in Section 5.3.

- List of key operations

Name	Content
RUN/STOP key	NA
DSP.CHG key	NA
Dig.MOVE key	NA
AUTO/MAN key	NA
RESET key	NA
MODE key	NA
▽ key	NA
△ key	NA

- Base screen

Segment	Content
PV	The input type displayed is the maximum value within the display range or the scaling upper limit.
Others	Go off.

Lamp	Content
All	Go off.

< In the case of the temperature input (K thermocouple) >

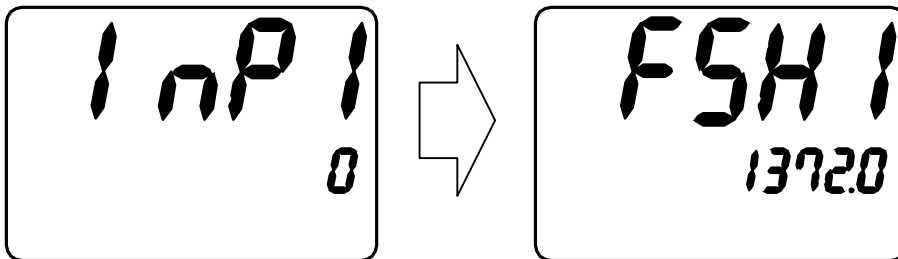

< In the case of the analog input (4 to 20 mADC) >

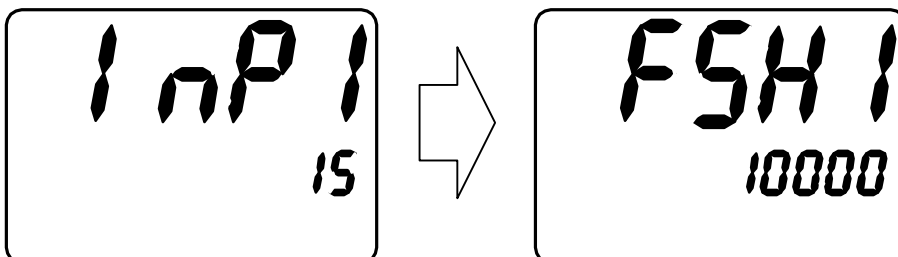

	DWG No. 48-7000-F	PAGE 9/72
--	----------------------	--------------

### 5.3 Normal mode

- In the run mode, four statuses are possible: Reset, auto run, temporary stop and manual run.
- The reset results in in-a-shutdown, auto run and temporary stop; the manual run results in in-a-run.

#### 5.3.1 Reset (normal mode)

- Upon 4 seconds elapsed in the initial mode, the mode screen changes to this one.
- Pressing the DISP.CHG key results in a change to the pattern No. setting mode described in Section 5.4.
- Holding the MODE key pressed for 3 seconds results in a change to the common parameter setting mode described in Section 5.6.
- Holding the MODE key and ▽ key pressed for 3 seconds results in a change to the alarm temperature setting mode described in Section 5.7.
- Holding the MODE key and △ key pressed for 3 seconds results in a change to the PID setting mode described in Section 5.8.
- Holding the RUN/STOP key pressed for 2 seconds results in the start of a run and a change to the auto run status described in Section 5.3.2.
- Holding the AUTO/MAN key pressed for 3 seconds results in a change to the manual run status described in Section 5.3.4.
- At existence of abnormality, pressing the RESET key releases it (provided that the abnormality is in a released status.)

- List of key operations

Name	Content
RUN/STOP key	NA
DSP.CHG key	Changes to the pattern No. setting mode.
Dig.MOVE key	NA
AUTO/MAN key	NA
RESET key	NA
MODE key	NA
▽ key	NA
△ key	NA
MODE key for 3 seconds	Changes to the common parameter setting mode.
MODE key + ▽ key for 3 seconds	Changes to the alarm temperature setting mode.
MODE key + △ key for 3 seconds	Changes to the PID setting mode.
RUN/STOP key for 2 seconds	Starts a run.
AUTO/MAN key for 3 seconds	Switches over to MANU and the manual run starts.

- Base screen

< PV/SV screen >

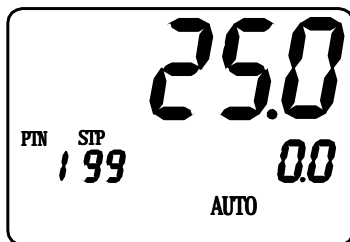

Segment	Content
PV	Displays a measured temperature.
SV	Displays "0.0."
Pattern digit	Displays a pattern No. in selection.
Step digit	Displays the number of steps of the pattern in selection.
Operating status	Goes off.

Lamp	Content
PTN STP AUTO	Lights up.
Others	Go off

### 5.3.2 Auto run (normal mode)

- The mode screen changes to this one when a run is started according to Section 5.3.1 “Reset.”
- Holding the DSP.CHG key pressed for 3 seconds results in a change to the pattern No. setting mode described in Section 5.4.
- Holding the MODE key pressed for 3 seconds results in a change to the common parameter setting mode described in Section 5.6.
- Holding the MODE key and ▽ key pressed for 3 seconds results in a change to the alarm temperature setting mode described in Section 5.7.
- Holding the MODE key and △ key pressed for 3 seconds results in a change to the PID setting mode described in Section 5.8.
- Holding the RESET key pressed for 2 seconds results in a stop of the run and a change to the reset status described in Section 5.3.1.
- Pressing the RUN/STOP key results in a change to the temporary stop status described in Section 5.3.3.
- Holding the AUTO/MAN key pressed for 3 seconds results in a change to the manual run status described in Section 5.3.4.
- At existence of abnormality, pressing the RESET key releases it (provided that the abnormality is in a released status.)
- Each time when the DSP.CHG key is pressed, display switches over to PV/SV Display, Elapsed Time, Operation Amount 1 or Operation Amount 2 in sequence.
- At an elapsed time displayed, pressing the △ or ▽ key enables fast feed or fast return.

#### – List of key operations

Name	Content
RUN/STOP key	Changes to the temporary stop mode.
DSP.CHG key	Switches over the display to PV/SV Display, Elapsed Time, Operation Amount 1 or Operation Amount 2.
Dig.MOVE key	Shifts the digit on the elapsed time screen.
AUTO/MAN key	NA
RESET key	NA
MODE key	NA
▽ key	Elapsed time display screen: Fast return of the elapsed time.
△ key	Elapsed time display screen: Fast feed of the elapsed time.
DSP.CHG key for 3 seconds	Changes to the pattern No. setting mode.
MODE key for 3 seconds	Changes to the common parameter setting mode.
MODE key + ▽ key for 3 seconds	Changes to the alarm temperature setting mode.
MODE key + △ key for 3 seconds	Changes to the PID setting mode.
RESET key for 2 seconds	Terminates a run.
AUTO/MAN key for 3 seconds	Starts a manual run.
▽ key for 3 seconds	PV/SV screen: Step return
△ key for 3 seconds	PV/SV screen: Step feed

	DWG No. 48-7000-F	PAGE 11/72
--	----------------------	---------------

- Base screen  
< PV/SV screen >

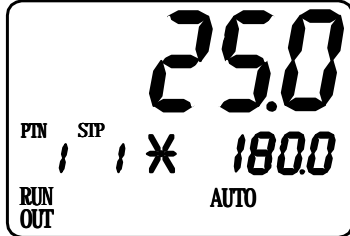

Segment	Content
PV	Displays a measured temperature.
SV	Displays the present setting temperature; blinks during wait; displays "TIME" during a run in Step 1 Timer.
Pattern digit	Displays a pattern No. in selection.
Step digit	Displays the number of steps presently in progress.
Operating status	Displays the status of a step presently in progress.

Lamp	Content
PTN STP RUN AUTO	Lights up.
OUT	Lights up only at the heating output.
AT END TIME MANU	Goes off.
EV1 to EV4 TS1 to TS4	Lights up/goes off in accordance with the content described in Section 3.3 "Lamp display section."

< Elapsed Time >

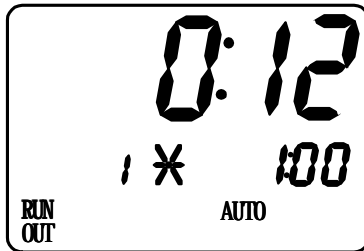

Segment	Content
PV	Displays elapsed time (blink of colon).
SV	Displays the setting time of a step in selection.
Pattern digit	Displays the number of run count presently in progress.
Step digit	
Operating status	Displays the status of a step presently in progress.

Lamp	Content
Same as the PV/SV screen	

< Operation Amount 1 and Operation Amount 2 >

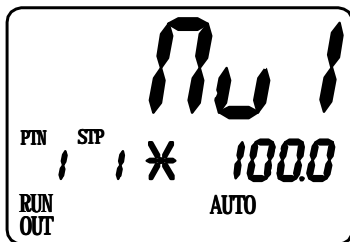

Segment	Content
PV	Displays characters.
SV	Displays the operation amount presently in output.
Pattern digit	Displays a pattern No. in selection.
Step digit	Displays the number of steps presently in progress.
Operating status	Displays the status of a step presently in progress.

Lamp	Content
Same as the PV/SV screen	

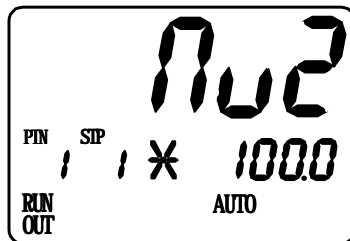

### 5.3.3 Temporary stop (normal mode)

- This mode screen appears by pressing the RUN/STOP key in the auto run status described in Section 5.3.2. The step time comes to a stop status.
- Holding the DSP.CHG key pressed for 3 seconds results in a change to the pattern No. setting mode described in Section 5.4.
- Holding the MODE key pressed for 3 seconds results in a change to the common parameter setting mode described in Section 5.6.
- Holding the MODE key and ▽ key pressed for 3 seconds results in a change to the alarm temperature setting mode described in Section 5.7.
- Holding the MODE key and △ key pressed for 3 seconds results in a change to the PID setting mode described in Section 5.8.
- Holding the RESET key pressed for 2 seconds results in a stop of the run and a change to the reset status described in Section 5.3.1.
- Pressing the RUN/STOP key results in a change to the run status described in Section 5.3.2
- Holding the AUTO/MAN key pressed for 3 seconds results in a change to the manual run status described in Section 5.3.4.
- At existence of abnormality, pressing the RESET key releases it (provided that the abnormality is in a released status.)
- Each time when the DSP.CHG key is pressed, display switches over to PV/SV Display, Elapsed Time, Operation Amount 1 or Operation Amount 2 in sequence.
- At an elapsed time displayed, pressing the △ or ▽ key enables fast feed or fast return.

#### – List of key operations

Name	Content
RUN/STOP key	Changes to the run status.
DSP.CHG key	Switches over the display to PV/SV Display, Elapsed Time, Operation Amount 1 or Operation Amount 2.
Dig.MOVE key	Shifts the digit on each screen of Elapsed Time/Operation Amount.
AUTO/MAN key	NA
RESET key	NA
MODE key	NA
▽ key	Elapsed time display screen: Fast return of the elapsed time.
△ key	Elapsed time display screen: Fast feed of the elapsed time.
DSP.CHG key for 3 seconds	Changes to the pattern No. setting mode.
MODE key for 3 seconds	Changes to the common parameter setting mode.
MODE key + ▽ key for 3 seconds	Changes to the alarm temperature setting mode.
MODE key + △ key for 3 seconds	Changes to the PID setting mode.
RESET key for 2 seconds	Terminates a run.
AUTO/MAN key for 3 seconds	Starts a manual run.
▽ key for 3 seconds	PV/SV screen: Step return
△ key for 3 seconds	PV/SV screen: Step feed

	DWG No. 48-7000-F	PAGE 13/72
--	----------------------	---------------

- Base screen  
< PV/SV screen >

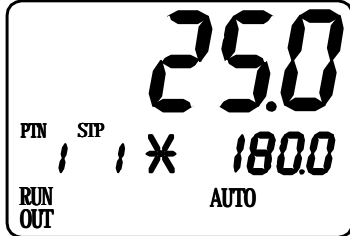

Segment	Content
PV	Displays a measured temperature.
SV	Displays the present setting temperature; blinks during wait.
Pattern digit	Displays a pattern No. in selection.
Step digit	Displays the number of steps presently in progress.
Operating status	Displays the status of a step presently in progress.

Lamp	Content
PTN STP AUTO	Lights up.
RUN	Blinks
OUT	Lights up only at the heating output.
AT END TIME MANU	Goes off.
EV1 to EV4 TS1 to TS4	Lights up/goes off in accordance with the content described in Section 3.3 "Lamp display section."

< Elapsed Time >

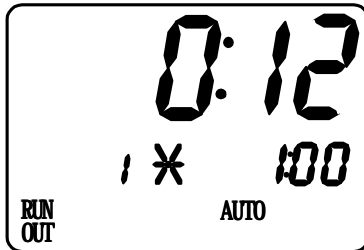

Segment	Content
PV	Displays elapsed time (blink of colon).
SV	Displays the setting time of a step in selection.
Pattern digit	Displays the number of run count presently in progress.
Step digit	
Operating status	Displays the status of a step presently in progress.

Lamp	Content
Same as the PV/SV screen	

< Operation Amount 1 and Operation Amount 2 >

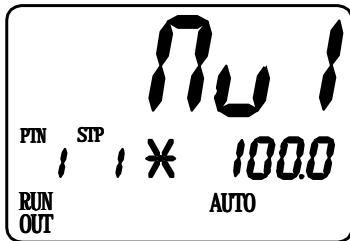

Segment	Content
PV	Displays characters.
SV	Displays the operation amount presently in output.
Pattern digit	Displays a pattern No. in selection.
Step digit	Displays the number of steps presently in progress.
Operating status	Displays the status of a step presently in progress.

Lamp	Content
Same as the PV/SV screen	

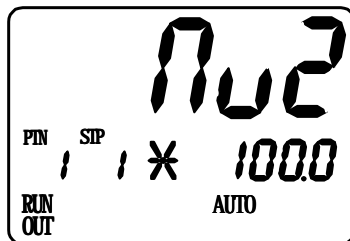

### 5.3.4 Manual run (normal mode)

- This mode screen appears by holding the AUTO/MAN key pressed for 3 seconds in the reset status described in Section 5.3.1. The output operation amount begins with 0.0%.
- This mode screen appears by holding the AUTO/MAN key pressed for 3 seconds in the run status described in Section 5.3.2 or the temporary stop status described in Section 5.3.3. The output operation amount becomes the amount at the change, and the step time comes to a continuous status.
- Holding the DSP.CHG key pressed for 3 seconds results in a change to the pattern No. setting mode described in Section 5.4.
- Holding the MODE key pressed for 3 seconds results in a change to the common parameter setting mode described in Section 5.6.
- Holding the MODE key and ▽ key pressed for 3 seconds results in a change to the alarm temperature setting mode described in Section 5.7.
- Holding the MODE key and △ key pressed for 3 seconds results in a change to the PID setting mode described in Section 5.8.
- Pressing the ▽ key in the PV/SV screen decreases the operation amount.
- Pressing the △ key in the PV/SV screen increases the operation amount.
- Holding the AUTO/MAN key pressed for 3 seconds results in a return to the previous screen (Reset, Auto Run or Temporary Stop).
- At existence of abnormality, pressing the RESET key releases it (provided that the abnormality is in a released status.)
- Each time when the DSP.CHG key is pressed, display switches over to PV/SV Display, Elapsed Time, Operation Amount 1 or Operation Amount 2 in sequence.  
(No elapsed time is displayed during a manual run.)

#### – List of key operations

Name	Content
RUN/STOP key	NA
DSP.CHG key	Switches over the display to PV/SV Display, Elapsed Time, Operation Amount 1 or Operation Amount 2. (No elapsed time is displayed during a manual run.)
Dig.MOVE key	Shifts the digit.
AUTO/MAN key	NA
RESET key	NA
MODE key	NA
▽ key	PV/SV display screen: Decreases the operation amount 1. Elapsed Time display screen (at step time continuation): Elapsed time fast return Operation Amount 1 display screen: Decreases the operation amount 1. Operation Amount 2 display screen: Decreases the operation amount 2.
△ key	PV/SV display screen: Increases the operation amount 1. Elapsed Time display screen (at step time continuation): Elapsed time fast feed Operation Amount 1 display screen: Increases the operation amount 1. Operation Amount 2 display screen: Increases the operation amount 2.
DSP.CHG key for 3 seconds	Changes to the pattern No. setting mode.
MODE key for 3 seconds	Changes to the common parameter setting mode.
MODE key + ▽ key for 3 seconds	Changes to the alarm temperature setting mode.
MODE key + △ key for 3 seconds	Changes to the PID setting mode.
AUTO/MAN key for 3 seconds	Terminates the manual run to return to the auto run; returns to the previous screen.

	DWG No. 48-7000-F	PAGE 15/72
--	----------------------	---------------

- Base screen  
< PV/SV screen >

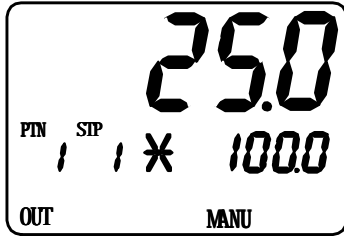

Segment	Content
PV	Displays a measured temperature.
SV	Displays the present setting temperature.
Pattern digit	Displays a pattern No. in selection.
Step digit	Displays the number of steps presently in progress.
Operating status	Displays the status of a step presently in progress.

Lamp	Content
PTN STP MANU	Lights up.
OUT	Lights up only at the heating output.
RUN	In a stop: Goes off. In a run: Lights up. In a temporary stop: Blinks.
AT END TIME	Go off.
EV1 to EV4 TS1 to TS4	Lights up/goes off in accordance with the content described in Section 3.3 "Lamp display section."

< Elapsed Time >

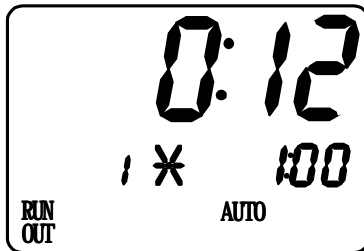

Segment	Content
PV	Displays elapsed time.
SV	Displays the setting time of a step in selection.
Pattern digit	Displays the number of run count presently in progress.
Step digit	
Operating status	Displays the status of a step presently in progress.

Lamp	Content
Same as the PV/SV screen	

< Operation Amount 1 and Operation Amount 2 >

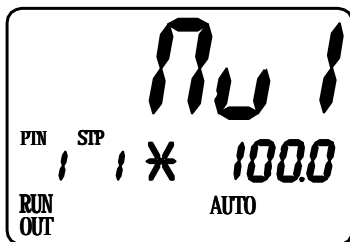

Segment	Content
PV	Displays characters.
SV	Displays the operation amount presently in output.
Pattern digit	Displays a pattern No. in selection.
Step digit	Displays the number of steps presently in progress.
Operating status	Displays the status of a step presently in progress.

Lamp	Content
Same as the PV/SV screen	

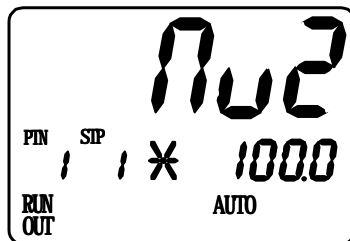

#### 5.4 Pattern No. setting mode

- This mode screen appears by pressing the DSP.CHG key (to be held for 3 seconds in a run) in the normal mode described in Section 5.3.
- Pressing the RESET key results in a return to the normal mode described in Section 5.3.
- Select the pattern No. by using the ▽ or △ key. However, no change is possible during a run (“RUN” is displayed in the SV indication digit).
- Pressing the MODE key confirms the pattern No., resulting in a change to the program setting mode described in Section 5.5.
- Holding the RUN/STOP key pressed for 2 seconds during a stop results in a start of a run.

##### – List of key operations

Name	Content
RUN/STOP key	NA
DSP.CHG key	NA
Dig.MOVE key	NA
AUTO/MAN key	NA
RESET key	Returns to the normal mode.
MODE key	Confirms the pattern No.; changes to the program setting mode.
▽ key	Decrements the program No.
△ key	Increments the program No.
RUN/STOP key for 2 seconds	Starts a run.

##### – Base screen



Segment	Content
PV	Displays characters.
SV	Displays a pattern No.
Pattern digit	Goes off.
Step digit	Goes off.
Operating status	Displays the program run status.

Lamp	Content
PTN	Lights up.
STP	Goes off.
Others	Light up/go off in accordance with the content described in Section 3.3 “Lamp display section.”

## 5.5 Program setting mode

- This mode screen appears by pressing the MODE key in the pattern No. setting mode described in Section 5.4.
- Pressing the RESET key results in a return to the normal mode described in Section 5.3.
- Change the time or temperature of the displayed step by using the ▽ or △ key.
- During a run, steps other than those being executed for the run can only be changed. No change is possible with steps being executed (“RUN” is displayed in the SV indication digit).
- Pressing the MODE key confirms the changed setting and changes the item to the next one.
- If all setting temperatures for the selected pattern are 0, a change to the next SV setting item after a change of a SV results in setting the same SV beforehand.
- Pressing the DSP. CHG key and the MODE key together on the SV setting screen for each step results in a change to the hidden parameter item setting for each step.
- Hidden parameter setting is enabled for functions of wait, time signal 1 to 4 and operation amount limiter. Pressing the MODE key results in confirmation of the changed setting and a change to the next item.
- With the operation amount limiter function, pressing the MODE key results in confirmation of the changed setting and a change to the step time setting for each step.
- Pressing the △ key while pressing the MODE key results in a return to one previous setting item (hidden setting is excluded).
- Holding the RUN/STOP key pressed for 2 seconds during a stop results in a start of a run.

### – List of key operations

Name	Content
RUN/STOP key	NA
DSP.CHG key	NA
Dig.MOVE key	Increments the digit of a setting value.
AUTO/MAN key	NA
RESET key	Returns to the normal mode.
MODE key	Confirms a changed value and changes the item to the next one.
▽ key	Decreases a setting value.
△ key	Increases a setting value.
RUN/STOP key for 2 seconds	Starts a run.
DSP.CHG key + MODE key	Changes the item to a hidden parameter item in case of a SV setting item.
MODE key + △ key	Changes the item to one previous setting item (hidden setting is excluded).

### – Base screen

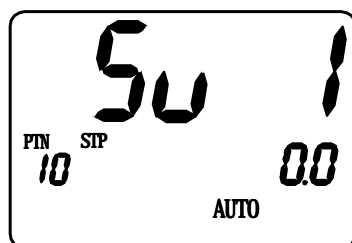

Segment	Content
PV	Displays characters (see the next page).
SV	Displays a setting value.
Pattern digit	Displays the pattern No. presently in display.
Step digit	Goes off.
Operating status	Displays the program run status.

Lamp	Content
PTN, STP	Lights up.
Others	Light up/go off in accordance with the content described in Section 3.3 “Lamp display section.”

	DWG No. 48-7000-F	PAGE 18/72
--	----------------------	---------------

- List of displays

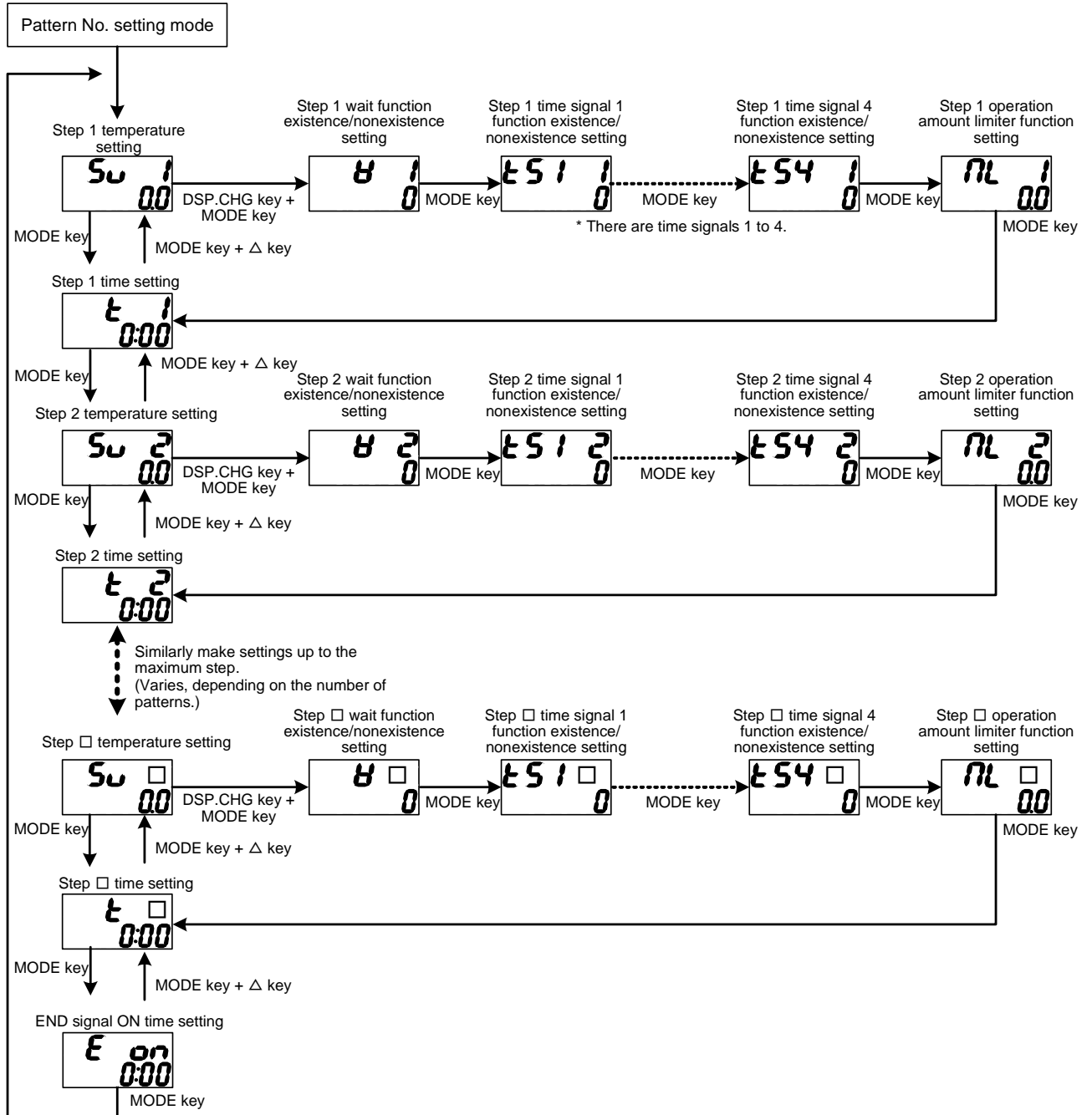

## 5.6 Common parameter setting mode

- Prolonged pressing the MODE key for 3 seconds in the normal mode described in Section 5.3 results in a change to this mode screen.
- Pressing the RESET key results in a return to the normal mode described in Section 5.3.
- The setting item or the setting value is changed by using the ▽ or △ key.
- Pressing the MODE key confirms the changed setting and changes the item to the next one.
- Holding the RUN/STOP key pressed for 2 seconds during a stop results in a start of a run.

### – List of key operations

Name	Content
RUN/STOP key	NA
DSP.CHG key	NA
Dig.MOVE key	Increments the digit of a setting value.
AUTO/MAN key	NA
RESET key	Returns to the normal mode.
MODE key	Confirms a changed value and changes the item to the next one.
▽ key	Decreases a setting value.
△ key	Increases a setting value.
RUN/STOP key for 2 seconds	Starts a run.

### – Base screen

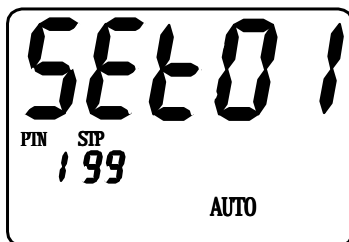

Segment	Content
PV	Displays characters (see the next page).
SV	Goes off in the mode selection screen. Displays a setting value for each item.
Others	Light up/go off in accordance with the content described in Section 3.2 “Segment display section.”

Lamp	Content
PTN, STP	Lights up.
Others	Light up/go off in accordance with the content described in Section 3.3 “Lamp display section.”

	DWG No. 48-7000-F	PAGE 20/72
--	----------------------	---------------

- List of displays

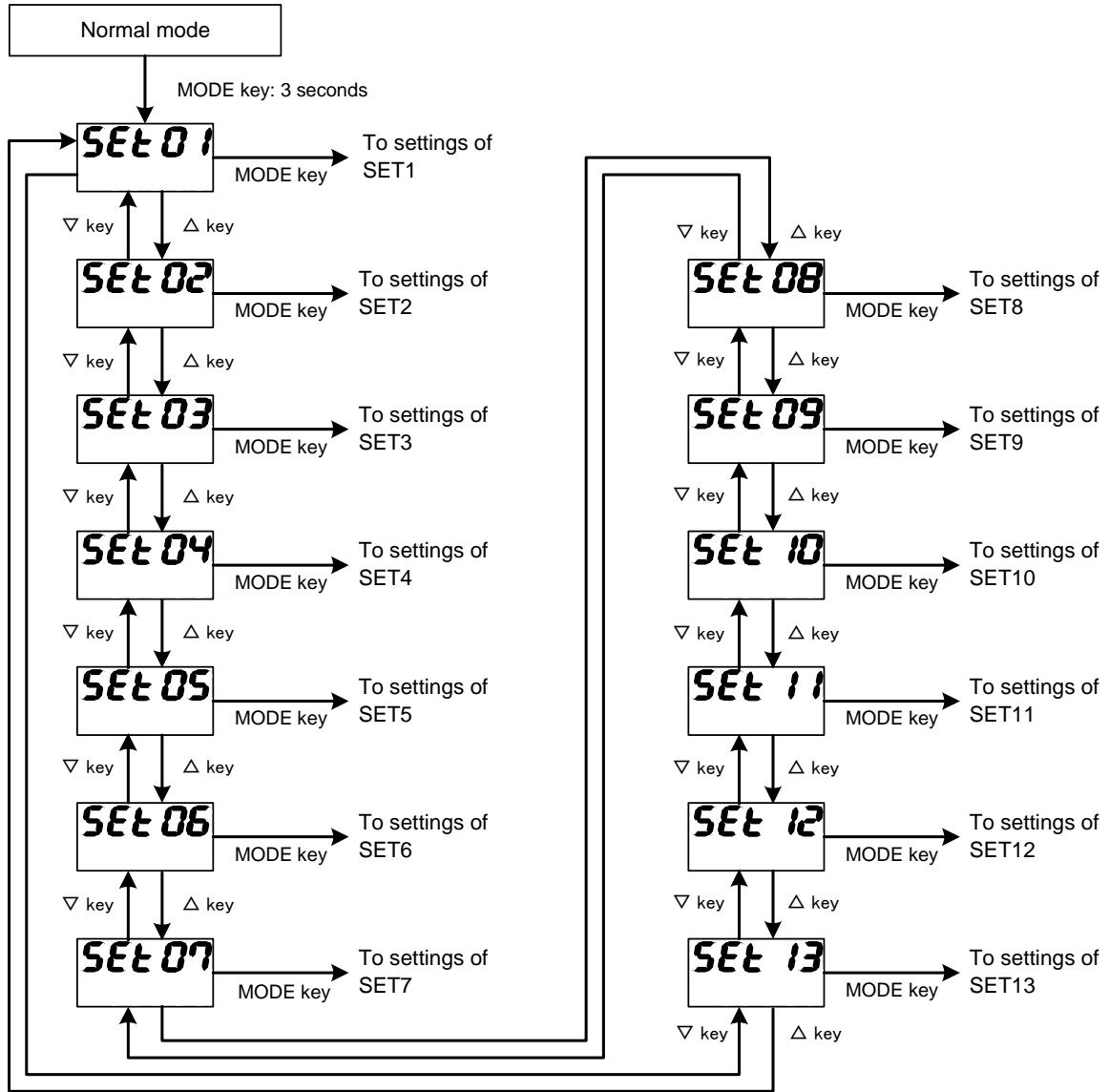

## 5.7 Alarm temperature setting mode

- Prolonged pressing the MODE key and ▽ key for 3 seconds in the normal mode described in Section 5.3 results in a change to this mode screen.  
However, if all of the events 1 to 4 functions are not provided with the product, no change is made.  
Existence/nonexistence of an upper limit setting or lower limit display is determined by the alarm type.
- Pressing the RESET key results in a return to the normal mode described in Section 5.3.
- A setting value for each item is changed by using the ▽ or △ key.
- Pressing the MODE key confirms the changed setting and changes the item to the next one.
- Holding the RUN/STOP key pressed for 2 seconds during a stop results in a start of a run.

### – List of key operations

Name	Content
RUN/STOP key	NA
DSP.CHG key	NA
Dig.MOVE key	Increments the digit of a setting value.
AUTO/MAN key	NA
RESET key	Returns to the normal mode.
MODE key	Confirms a changed value and changes the item to the next one.
▽ key	Decreases a setting value.
△ key	Increases a setting value.
RUN/STOP key for 2 seconds	Starts a run.

### – Base screen

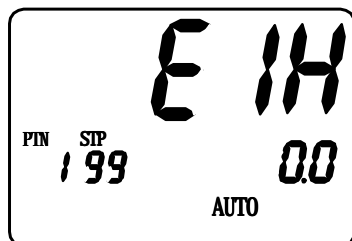

Segment	Content
PV	Displays characters (see the next page).
SV	Displays a setting value for each item.
Others	Light up/go off in accordance with the content described in Section 3.2 "Segment display section."

Lamp	Content
PTN, STP	Lights up.
Others	Light up/go off in accordance with the content described in Section 3.3 "Lamp display section."

	DWG No. 48-7000-F	PAGE 22/72
--	----------------------	---------------

- List of displays

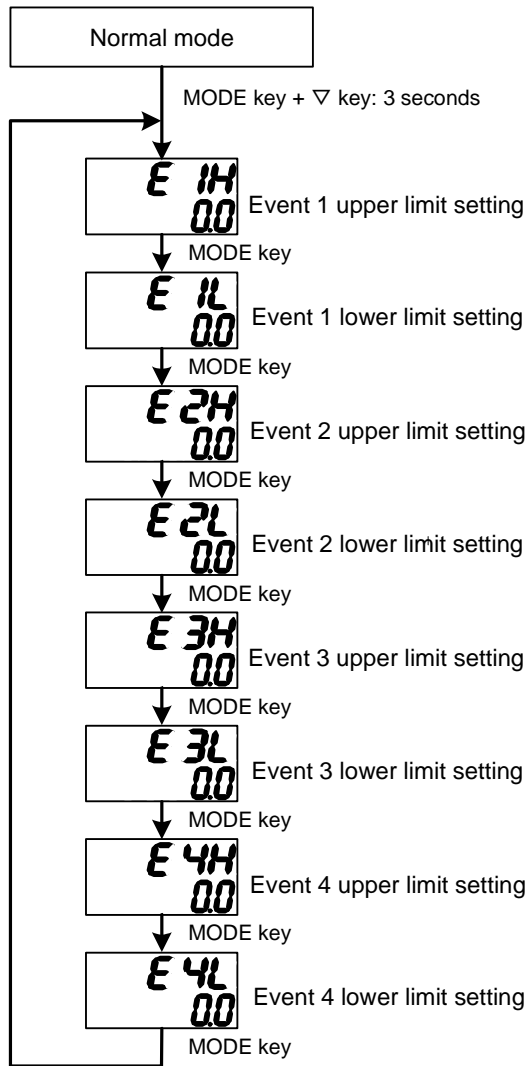

## 5.8 PID setting mode

- Prolonged pressing the MODE key +  $\Delta$  key for 3 seconds in the normal mode described in Section 5.3 results in a change to this mode screen.
- Pressing the RESET key results in a return to the normal mode described in Section 5.3.
- A setting value for each item is changed by using the  $\nabla$  or  $\Delta$  key.
- Pressing the MODE key confirms the changed setting and changes the item to the next one.
- Holding the RUN/STOP key pressed for 2 seconds during a stop results in a start of a run.

### – List of key operations

Name	Content
RUN/STOP key	NA
DSP.CHG key	NA
Dig.MOVE key	Increments the digit of a setting value.
AUTO/MAN key	NA
RESET key	Returns to the normal mode.
MODE key	Confirms a changed value and changes the item to the next one.
$\nabla$ key	Decreases a setting value.
$\Delta$ key	Increases a setting value.
RUN/STOP key for 2 seconds	Starts a run.

### – Base screen

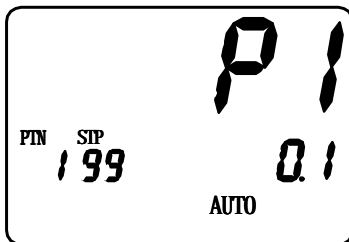

Segment	Content
PV	Displays characters (see the next page).
SV	Displays a setting value for each item.
Others	Light up/go off in accordance with the content described in Section 3.2 "Segment display section."

Lamp	Content
PTN, STP	Lights up.
Others	Light up/go off in accordance with the content described in Section 3.3 "Lamp display section."

	DWG No. 48-7000-F	PAGE 24/72
--	----------------------	---------------

- List of displays

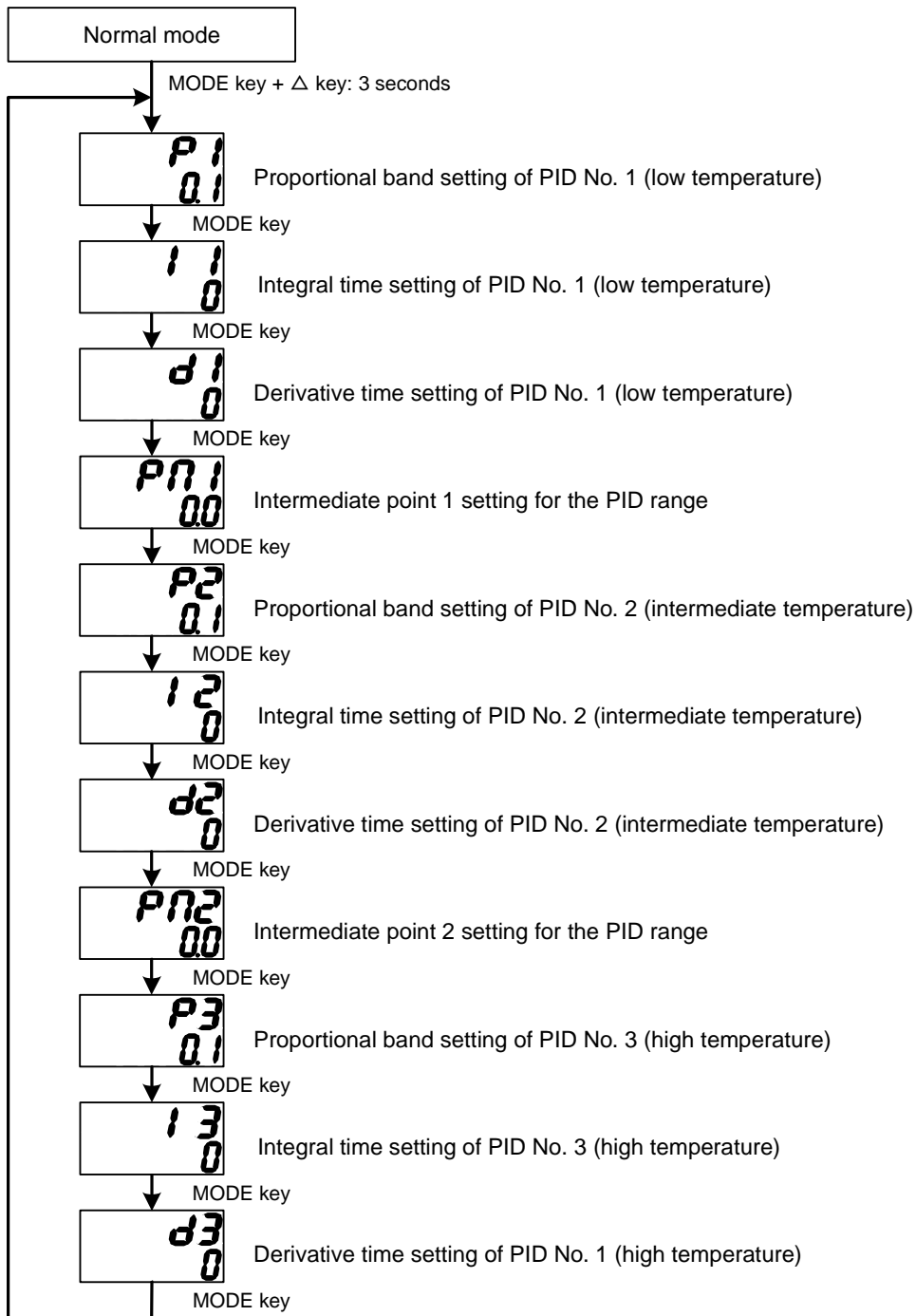

	DWG No. 48-7000-F	PAGE 25/72
--	----------------------	---------------

## 6. List of Setting Values

### 6.1 List of settings in the pattern No. setting and program setting modes

		Name	Setting content	Initial value
1	<b>SV *</b>	Setting temperature (*1)	- (Termination of a run); <b>SLL to SLH</b>	<b>0</b>
2	<b>W *</b>	Wait function setting (*1)	0 to 4 (0 stands for no function)	<b>0</b>
3	<b>TS1 *</b>	Time signal 1 function setting (*1)	0 to 5 (0 stands for no function and 5 for in-a-selection step ON)	<b>0</b>
4	<b>TS2 *</b>	Time signal 2 function setting (*1)	0 to 5 (0 stands for no function and 5 for in-a-selection step ON)	<b>0</b>
5	<b>TS3 *</b>	Time signal 3 function setting (*1)	0 to 5 (0 stands for no function and 5 for in-a-selection step ON)	<b>0</b>
6	<b>TS4 *</b>	Time signal 4 function setting (*1)	0 to 5 (0 stands for no function and 5 for in-a-selection step ON)	<b>0</b>
7	<b>ML *</b>	Operation amount limiter function setting (*1)	0 to 4 (0 stands for no function)	<b>0</b>
8	<b>T *</b>	Setting time (*1)	0:00 to 99:59 (hour: minute); - (endless setting)	<b>00:00</b>
9	<b>RNC</b>	running times	0 - 99 times (0 for infinite number)	<b>1</b>
10	<b>E ON</b>	End signal ON time	0:00 to 99:59 (hour: minute); - (ON hold)	<b>00:00</b>

### 6.2 Common parameter setting mode SET 1

	SET01	Name	Setting content	Initial value
1	<b>PAT</b>	Number-of-patterns setting (*2) (*3)	1 to 15 (pattern)	<b>1</b>
2	<b>PVSV</b>	PV start/SV start selection (*2)	<b>PV</b> PV start <b>SV</b> SV start	<b>PV</b>
3	<b>SVSV</b>	Start temperature setting at SV start (*2)	Thermocouple/resistance temperature detector input <b>SLL to SLH</b> (°C) Current/voltage input <b>SLL to SLH</b> (digit)	<b>0</b>
4	<b>RNES</b>	In-a-run output/end signal output selection (*2)	0 In-a-run output 1 End signal output	<b>0</b>
5	<b>ERUN</b>	External drive signal selection (*2)	<b>OFF</b> Internal run <b>ON</b> External run	<b>OFF</b>
6	<b>TPV</b>	Power outage restoration temperature width setting	Thermocouple/resistance temperature detector input 0.0 to 2999.9 (°C) or 0 to 2999 (°C) Current/voltage input 0 to 29999 (digit)	<b>0</b>

	DWG No. 48-7000-F	PAGE 26/72
--	----------------------	---------------

### 6.3 Common parameter setting mode SET 2

	SET02	Name	Setting content	Initial value
* Below, 1 and 2 are for the wait function setting, i.e., effective when 1 is selected.				
1	WZ1	Wait zone 1 setting	Thermocouple/resistance temperature detector input 0.0 to 999.9 (°C) or 0 to 999 (°C)	0
			Current/voltage input 0 to 9999 (digit)	
2	WT1		Wait time 1 setting	
* Below, 3 and 4 are for the wait function setting, i.e., effective when 2 is selected.				
3	WZ2	Wait zone 2 setting	Thermocouple/resistance temperature detector input 0.0 to 999.9 (°C) or 0 to 999 (°C)	0
			Current/voltage input 0 to 9999 (digit)	
4	WT2		Wait time 2 setting	
* Below, 5 and 6 are for the wait function setting, i.e., effective when 3 is selected.				
5	WZ3	Wait zone 3 setting	Thermocouple/resistance temperature detector input 0.0 to 999.9 (°C) or 0 to 999 (°C)	0
			Current/voltage input 0 to 9999 (digit)	
6	WT3		Wait time 3 setting	
* Below, 7 and 8 are for the wait function setting, i.e., effective when 4 is selected.				
7	WZ4	Wait zone 4 setting	Thermocouple/resistance temperature detector input 0.0 to 999.9 (°C) or 0 to 999 (°C)	0
			Current/voltage input 0 to 9999 (digit)	
8	WT4		Wait time 4 setting	

### 6.4 Common parameter setting mode SET 3

	SET03	Name	Setting content	Initial value
* Below, 1 and 2 are for the time signal function setting, i.e., effective when 1 is selected.				
1	ONT1	Time signal ON delay timer 1	0:00 to 99:59 (hours:minutes)	00:00
2	OFT1	Time signal OFF delay timer 1	0:00 to 99:59 (hours:minutes)	00:00
* Below, 3 and 4 are for the time signal function setting, i.e., effective when 2 is selected.				
3	ONT2	Time signal ON delay timer 2	0:00 to 99:59 (hours:minutes)	00:00
4	OFT2	Time signal OFF delay timer 2	0:00 to 99:59 (hours:minutes)	00:00
* Below, 5 and 6 are for the time signal function setting, i.e., effective when 3 is selected.				
5	ONT3	Time signal ON delay timer 3	0:00 to 99:59 (hours:minutes)	00:00
6	OFT3	Time signal OFF delay timer 3	0:00 to 99:59 (hours:minutes)	00:00
* Below, 7 and 8 are for the time signal function setting, i.e., effective when 4 is selected.				
7	ONT4	Time signal ON delay timer 4	0:00 to 99:59 (hours:minutes)	00:00
8	OFT4	Time signal OFF delay timer 4	0:00 to 99:59 (hours:minutes)	00:00

	DWG No. 48-7000-F	PAGE 27/72
--	----------------------	---------------

## 6.5 Common parameter setting mode SET 4 (1)

	SET04	Name	Setting content	Initial value
1	SLH	SV limiter upper limit (*2) (*3)	Thermocouple/resistance temperature detector input (SLL + 5.0) to SV setting range upper limit (°C) (SLL + 5) to SV setting range upper limit (°C)	1200
			Current/voltage input (SLL + 50) to SV setting range upper limit (digit)	12000
2	SLL	SV limiter lower limit (*2) (*3)	Thermocouple/resistance temperature detector input SV setting range lower limit to (SLH - 5.0) (°C) SV setting range lower limit to (SLH - 5) (°C)	0
			Current/voltage input (SLH - 50) to SV setting range lower limit (digit)	
3	CNT	Control type setting	1 Primary...pid control                      Secondary---None	1
			2 Primary---onoff control                      Secondary---None	
			3 Primary---pid control                      Secondary---pid control	
			4 Primary---pid control                      Secondary---onoff control	
			5 Primary---onoff control                      Secondary---onoff control	
4	DIR	Forward/reverse operation setting	0 Reverse operation	0
			1 Forward operation	
5	MV1	Primary control operating amount	0.0 to 100.0 (%)	0.0
6	TUN	Tuning type setting	1 Primary auto-tuning	1
			2 Secondary auto-tuning	
			3 Primary/secondary auto-tuning	
7	ATG	AT coefficient setting	0.1 to 10.0 (times)	1.0
8	ATC	AT sensitivity setting	Thermocouple/resistance temperature detector input 0.0 to 999.9 (°C) 0 to 999 (°C)	2
			Voltage/current input 0 to 9999 (digit)	
9	AT1	AT startup screen for PID No. 1 (low temperature)	Startup starts/stops by setting a SV and using the RUN/STOP key. Characters and PV are alternately displayed in the PV digit during AT. The SV range is SLL to PM1.	0
10	AT2	AT startup screen for PID No. 2 (intermediate temperature)	Startup starts/stops by setting a SV and using the RUN/STOP key. Characters and PV are alternately displayed in the PV digit during AT. The SV range is PM1 to PM2.	0
11	AT3	AT startup screen for PID No. 3 (high temperature)	Startup starts/stops by setting a SV and using the RUN/STOP key. Characters and PV are alternately displayed in the PV digit during AT. The SV range is PM2 to SLH.	10
12	ATALL	AT startup screen for PID No. 1~3	Use the RUN/STOP key for start and stop. During the auto tuning, Character//PV is alternately displayed at PV display, and No. 1 - 3/SV are alternately displayed at SV display.	
13	P1	Proportional band setting for PID No. 1 (low temperature)	0.1 to 200.0 (%)	3.0
14	I1	Integral time setting for PID No. 1 (low temperature)	0 to 3600 (seconds)	0
15	D1	Derivative time setting for PID No. 1 (low temperature)	0 to 3600 (seconds)	0
16	PM1	Intermediate point 1 setting for the PID range	Thermocouple/resistance temperature detector input SLL to SLH- 5.0 (°C) SLL to SLH - 5 (°C)	0
			Current/voltage input SLL to SLH - 50 (digit)	0
17	P2	Proportional band setting for PID No. 2 (intermediate temperature)	0.1 to 200.0 (%)	3.0
18	I2	Integral time setting for PID No. 2 (intermediate temperature)	0 to 3600 (seconds)	0
19	D2	Derivative time setting for PID No. 2 (intermediate temperature)	0 to 3600 (seconds)	0
20	PM2	Intermediate point 2 setting for the PID range	PM1 to SLH (°C)	10

	DWG No. 48-7000-F	PAGE 28/72
--	----------------------	---------------

## 6.5 Common parameter setting mode SET 4 (2)

	SET04	Name	Setting content	Initial value
21	<b>P3</b>	Proportional band setting for PID No. 3 (high temperature)	0.1 to 200.0 (%)	<b>3.0</b>
22	<b>I3</b>	Integral time setting for PID No. 3 (high temperature)	0 to 3600 (seconds)	<b>0</b>
23	<b>D3</b>	Derivative time setting for PID No. 3 (high temperature)	0 to 3600 (seconds)	<b>0</b>
24	<b>T1</b>	Primary control proportional cycle	0.1 to 120.0 (seconds)	<b>1.0</b>
25	<b>ARW</b>	Anti-reset windup	0.0 to 110.0 (%) Function turned off at 110.0 (%) setting	<b>110.0</b>
26	<b>PS1</b>	Primary control loop abnormalityPV variation setting	Thermocouple/resistance temperature detector input	<b>0</b>
			0.0 to 999.9 (°C) or 0 to 999 (°C)	
			Current/voltage input	
			0 to 9999 (digit)	
27	<b>LOP1</b>	Primary control loop abnormality time setting	0 to 3600 (seconds)	<b>0</b>
28	<b>CMOD</b>	Primary control off-point position selection setting	0   SV unit setting	<b>0</b>
			1   Upper	
			2   Middle	
			3   Lower	
29	<b>C1</b>	Primary control sensitivity control	Thermocouple/resistance temperature detector input	<b>1</b>
			0.0 to 999.9 (°C) 0 to 999 (°C)	
			Current/voltage input	<b>10</b>
			0 to 9999 (digit)	
30	<b>CP1</b>	Primary control off-point position	Thermocouple/resistance temperature detector input	<b>0</b>
			-999.9 to 999.9 (°C) -999 to 999 (°C)	
			Current/voltage input	
			-9999 to 9999 (digit)	
31	<b>MV2</b>	Secondary control operating amount	0.0 to 100.0 (%)	<b>0.0</b>
32	<b>PC1</b>	Secondary control proportional band setting for PID No. 1 (low temperature)	0.10 to 10.00 (times)	<b>1.00</b>
33	<b>PC2</b>	Secondary control proportional band setting for PID No. 2 (intermediate temperature)	0.10 to 10.00 (times)	<b>1.00</b>
34	<b>PC3</b>	Secondary control proportional band setting for PID No. 3 (high temperature)	0.10 to 10.00 (times)	<b>1.00</b>
35	<b>T2</b>	Secondary control proportional cycle	0.1 to 120.0 (seconds)	<b>1.0</b>
36	<b>PS2</b>	Secondary control loop abnormality PV variation setting	Thermocouple/resistance temperature detector input	<b>0</b>
			0.0 to 999.9 (°C) or 0 to 999 (°C)	
			Current/voltage input	
			0 to 9999 (digit)	
37	<b>LOP2</b>	Secondary control loop abnormality time setting	0 to 3600 (seconds)	<b>0</b>
38	<b>C2</b>	Secondary control sensitivity setting	Thermocouple/resistance temperature detector input	<b>1</b>
			0.0 to 999.9 (°C) 0 to 999 (°C)	
			Current/voltage input	<b>10</b>
			0 to 9999 (digit)	
39	<b>CP2</b>	Secondary control off-point position	Thermocouple/resistance temperature detector input	<b>0</b>
			-999.9 to 999.9 (°C) -999 to 999 (°C)	
			Current/voltage input	
			-9999 to 9999 (digit)	
40	<b>PBB</b>	Manual reset	0.0 to 100.0 (%) when <b>CNT</b> = 1 -100.0 to 100.0 (%) when <b>CNT</b> = 3 and 4	<b>0.0</b>
41	<b>DB</b>	Dead band	Thermocouple/resistance temperature detector input	<b>0</b>
			-999.9 to 999.9 (°C) -999 to 999 (°C)	
			Current/voltage input	
			-9999 to 9999 (digit)	

	DWG No. 48-7000-F	PAGE 29/72
--	----------------------	---------------

### 6.5 Common parameter setting mode SET 4 (3)

	SET04	Name	Setting content	Initial value
42	01F	Target connection output 1 selection	Connection content selection	0
			0   MV1	
			1   MV2	
			2   Transmission output	
43	TRN1	Transmission output function setting	Transmission content selection	03
			*1   PV (measurement value) output	
			*2   SV (setting value) output	
			*3   MV 1 (Primary Control Amt.) output	
			*4   MV 2 (Secondary Control Amt.) output	
			Forward/reverse operation selection	
			0*   Forward operation	
			1*   Reverse operation	
44	TRH1	Transmission scaling upper limit setting	TRL1~2999.9( ) or TRL1~2999( )	1200
45	TRL1	Transmission scaling lower limit setting	-1999.9 ~ TRH1 ( ) or -1999 ~ TRH1 ( )	0
46	02F	Target connection setting 2	Connection content selection	1
			0   MV1	
			1   MV2	
			2   Transmission output	
47	TRN2	Transmission output function setting	Transmission content selection	04
			*1   PV (measurement value) output	
			*2   SV (setting value) output	
			*3   MV1 (Primary Control Amt.) output	
			*4   MV2 (Secondary Control Amt.) output	
			Forward/reverse operation selection	
			0*   Forward operation	
			1*   Reverse operation	
48	TRH2	Transmission scaling upper limit setting	TRL2~2999.9( ) or TRL2~2999( )	1200
49	TRL2	Transmission scaling lower limit setting	-1999.9 ~ TRH2 ( ) or -1999 ~ TRH2 ( )	0

	DWG No. 48-7000-F	PAGE 30/72
--	----------------------	---------------

## 6.6 Common parameter setting mode SET 5 to 8

	SET05 to SET08	Name	Setting content	Initial value	
1	E*F1	Event function 1 setting	Function	00	
			*0		None
			*1		Deviation upper and lower limits
			*2		Deviation upper limit
			*3		Deviation lower limit
			*4		Deviation range
			*5		Absolute value upper and lower limits
			*6		Absolute value upper limit
			*7		Absolute value lower limit
			*8		Absolute value range
			Add-on function		
			0*		None
			1*		Hold
			2*		Standby
			3*		Delay
4*	Hold + standby				
5*	Hold + Delay				
6*	Standby + Delay				
7*	Hold + standby + Delay				
2	E*H	Event upper limit setting	Thermocouple/resistance temperature detector input -1999.9 to 2999.9 (°C) -1999 to 2999 (°C) Note that for R, B and PR40-20 of thermocouple, the following is to be applied. -1999 to 9999 (°C)	0	
			Current/voltage input -19999 to 29999 (digit)		
3	E*L	Event lower limit setting	Thermocouple/resistance temperature detector input -1999.9 to 2999.9 (°C) -1999 to 2999 (°C) Note that for R, B and PR40-20 of thermocouple, the following is to be applied. -1999 to 9999 (°C)	0	
			Current/voltage input -19999 to 29999 (digit)		
4	E*C	Event sensitivity setting	Thermocouple/resistance temperature detector input 0.0 to 999.9 (°C) 0 to 999 (°C)	0	
			Current/voltage input 0 to 9999 (digit)		
5	E*T	Event Delay timer setting	0 to 9999 (second)	0	
6	E*F2	Event function 2 setting (loop abnormality)	Function	00	
			*0		Nonexistent
			*1		Existent
			Add-on function		
			0*		None
1*	Hold				
7	E*P	Event polarity setting	0	Normal open	0
			1	Normal close	

	DWG No. 48-7000-F	PAGE 31/72
--	----------------------	---------------

## 6.7 Common parameter setting mode SET 9 (1)

	SET09	Name	Setting content	Initial value
1	MLF	Operation amount function setting	0   None	0
			1   Operation amount limiter	
			2   Operation amount current limiter(average)	
			3   Operation amount current limiter(R.M.S)	
With the selection of [MLF =1], the following 2 to 9 are selectable for [CNT =1]; the following 2 to 17 are selectable for [CNT = 3 or 4]. * Below, 2 and 3 are for the operation amount limiter function setting, i.e., effective when 1 is selected.				
2	MLH11	Primary control operation amount limiter upper limit 1	MLL11 to 100.0(%)	100.0
3	MLL11	Primary control operation amount limiter lower limit 1	0.0 to MLH11(%)	0.0
* Below, 4 and 5 are for the operation amount limiter function setting, i.e., effective when 2 is selected.				
4	MLH21	Primary control operation amount limiter upper limit 2	MLL21 to 100.0(%)	100.0
5	MLL21	Primary control operation amount limiter lower limit 2	0.0 to MLH21(%)	0.0
* Below, 6 and 7 are for the operation amount limiter function setting, i.e., effective when 3 is selected.				
6	MLH31	Primary control operation amount limiter upper limit 3	MLL31 to 100.0(%)	100.0
7	MLL31	Primary control operation amount limiter lower limit 3	0.0 to MLH31(%)	0.0
* Below, 8 and 9 are for the operation amount limiter function setting, i.e., effective when 4 is selected.				
8	MLH41	Primary control operation amount limiter upper limit 4	MLL41 to 100.0(%)	100.0
9	MLL41	Primary control operation amount limiter lower limit 4	0.0 to MLH41(%)	0.0
* Below, 10 and 11 are for the operation amount limiter function setting, i.e., effective when 1 is selected.				
10	MLH12	Secondary control operation amount limiter upper limit 1	MLL12 to 100.0(%)	100.0
11	MLL12	Secondary control operation amount limiter lower limit 1	0.0 to MLH12(%)	0.0
* Below, 12 and 13 are for the operation amount limiter function setting, i.e., effective when 2 is selected.				
12	MLH22	Secondary control operation amount limiter upper limit 2	MLL22 to 100.0(%)	100.0
13	MLL22	Secondary control operation amount limiter lower limit 2	0.0 to MLH22(%)	0.0
* Below, 14 and 15 are for the operation amount limiter function setting, i.e., effective when 3 is selected.				
14	MLH32	Secondary control operation amount limiter upper limit 3	MLL32 to 100.0(%)	100.0
15	MLL32	Secondary control operation amount limiter lower limit 3	0.0 ~ MLH32(%)	0.0
* Below, 16 and 17 are for the operation amount limiter function setting, i.e., effective when 4 is selected.				
16	MLH42	Secondary control operation amount limiter upper limit 4	MLL42 to 100.0(%)	100.0
17	MLL42	Secondary control operation amount limiter lower limit 4	0.0 to MLH42(%)	0.0

	DWG No. 48-7000-F	PAGE 32/72
--	----------------------	---------------

## 6.7 Common parameter setting mode SET 9 (2)

	SET09	Name	Setting content	Initial value
With the selection of [MLF = 2,3], the following 18 to 41 are selectable.				
18	<b>CM1</b>	CT1 current value monitor	0.0 to 50.0 (A) Displays the average at MLF=2. Displays the R.M.S at MLF=3.	
19	<b>OH01</b>	Operation amount limiter point 1	A point is defined as a location corresponding to the number resulted from calculation of divided values of SLL to SLH into 10 equal segments multiplied by the point No. 0.0 to 100.0 (%)	<b>100.0</b>
20	<b>OH02</b>	Operation amount limiter point 2		
21	<b>OH03</b>	Operation amount limiter point 3		
22	<b>OH04</b>	Operation amount limiter point 4		
23	<b>OH05</b>	Operation amount limiter point 5		
24	<b>OH06</b>	Operation amount limiter point 6		
25	<b>OH07</b>	Operation amount limiter point 7		
26	<b>OH08</b>	Operation amount limiter point 8		
27	<b>OH09</b>	Operation amount limiter point 9		
28	<b>OH10</b>	Operation amount limiter point 10		
29	<b>OH11</b>	Operation amount limiter point 11		
30	<b>AH01</b>	Current value limiter point 1	Upper current limit at the operation amount limiter point 0.0 to 30.0 (A)	<b>30.0</b>
31	<b>AH02</b>	Current value limiter point 2		
32	<b>AH03</b>	Current value limiter point 3		
33	<b>AH04</b>	Current value limiter point 4		
34	<b>AH05</b>	Current value limiter point 5		
35	<b>AH06</b>	Current value limiter point 6		
36	<b>AH07</b>	Current value limiter point 7		
37	<b>AH08</b>	Current value limiter point 8		
38	<b>AH09</b>	Current value limiter point 9		
39	<b>AH10</b>	Current value limiter point 10		
40	<b>AH11</b>	Current value limiter point 11		
41	<b>AHC</b>	Current value limiter sensitivity	0.1 to 30.0 (A)	<b>0.2</b>
42 and 43 are always effective; 44 and 45 are selectable when [CNT = 3].				
42	<b>OU1</b>	Primary control operation amount increase rate	0.0 to 549.9 (%): 0.0% indicates the function turned off.	<b>0.0</b>
43	<b>OUTM1</b>	Primary control operation amount increase time	0 to 3600 (second): 0 indicates no function.	<b>0</b>
44	<b>OU2</b>	Secondary control operation amount increase rate	0.0 to 549.9 (%): 0.0% indicates the function turned off.	<b>0.0</b>
45	<b>OUTM2</b>	Secondary control operation amount increase time	0 to 3600 (second): 0 indicates no function.	<b>0</b>

	DWG No. 48-7000-F	PAGE 33/72
--	----------------------	---------------

## 6.8 Common parameter setting mode SET 10

	SET10	Name	Setting content	Initial value	
1	INP1	Input type setting (*2) (*3)	0	K thermocouple	0
			1	J thermocouple	
			2	T thermocouple	
			3	E thermocouple	
			4	R thermocouple	
			5	S thermocouple	
			6	B thermocouple	
			7	N thermocouple	
			8	U thermocouple	
			9	L thermocouple	
			10	WRe5-26	
			11	PR40-20	
			12	PLII	
			13	Pt100	
			14	JPt100	
			15	0 - 10 mV DC	
			16	0 - 1 V DC	
			17	0 - 5 V DC	
			18	1 - 5 V DC	
			19	0 - 10 V DC	
			20	4 - 20 mA DC	
2	FSH1	Scaling upper limit setting (*2) (*3)	Current/voltage input only FSL1 to 29999 (digit)	10000	
3	FSL1	Scaling lower limit setting (*2) (*3)	Current/voltage input only -19999 to FSH1 (digit)	-10000	
4	PVG1	PV compensation gain setting	0.500 to 2.000 (times)	1.000	
5	PVS1	PV compensation zero setting	Thermocouple/resistance temperature detector input -999.9 to 999.9 (°C) -999 to 999 (°C)	0	
			Current/voltage input -9999 to 9999 (digit)		
6	PDF1	PV filter setting	0.0 to 99.9 (seconds)	0.0	
7	PDFS	Special PV filter setting	0.0 to 99.9 (seconds)	0.0	
8	DP1	Decimal point position setting (*2) (*3)	Thermocouple/resistance temperature detector input	0	
			0		Unit of 1°C
			0.0		Unit of 0.1°C
			Current/voltage input		
			0		1/digit
			0.0		0.1/digit
			0.00		0.01/digit
			0.000		0.001/digit
			0.0000		0.0001/digit

## 6.9 Common parameter setting mode SET 11

	SET11	Name	Setting content	Initial value
1	BKUP	Backup of a setting value (*2) (*3)	Backup begins by holding the $\Delta$ and $\nabla$ keys pressed for 2 seconds. During the backup, "SAVE" is displayed; turn-off of the display indicates ended backup.	
2	RESET	Initialization of a setting value (*2)	Initialization of the backup setting begins by holding both $\Delta$ and $\nabla$ keys pressed for 2 seconds. During initialization, "LoAd" is displayed and turn-off of the display indicates ended initialization.	

	DWG No. 48-7000-F	PAGE 34/72
--	----------------------	---------------

### 6.10 Common parameter setting mode SET 12

	SET12	Name	Setting content	Initial value
1	PRT	Communication protocol setting	Press the MODE key for making a setting effective. 0 TOHO protocol 1 MODBUS protocol (RTU mode) 2 MODBUS protocol (ASCII mode)	0
2	COM	Communication parameter	***1 1 bit ***2 2 bits **N* None **0* Odd No. **E* Even No. *7** 7 bits For MODBUS(RTU) setting, 7bits is ineffective *8** 8 bits N*** Nonexistent (settable for TOHO protocol) B*** Existent (settable for TOHO protocol)	B8N2
3	BPS	Communication speed setting	2.4 2400 bps 4.8 4800 bps 9.6 9600 bps 19.2 19200 bps 38.4 38400 bps	9.6
4	ADR	Communication address setting	TOHO protocol 1 to 99 (stations) MODBUS protocol 1 to 247 (stations)	1
5	AWT	Communication response delay time setting	0 to 250 (ms)	0
6	MOD	Communication switchover setting	0 Write inhibit 1 Writable	1
7	SLV	Number-of-sub-controller-connections setting (*2)	0 to 10 (unit)	0

	DWG No. 48-7000-F	PAGE 35/72
--	----------------------	---------------

### 6.11 Common parameter setting mode SET 13

	SET13	Name	Setting content	Initial value
1	LOC-1	Normal screen lock setting	During the lock ON, an attempt of changing a setting results in "LOC" displayed on the screen.	0
2	LOC-2	Pattern No. setting mode lock setting		
3	LOC-3	Alarm temperature setting mode lock setting	0   Lock turned off	
4	LOC-4	PID setting mode lock setting	1   Lock turned on	
5	LOC01	Common parameter setting mode SET01 lock setting		
6	LOC02	Common parameter setting mode SET02 lock setting		
7	LOC03	Common parameter setting mode SET03 lock setting		
8	LOC04	Common parameter setting mode SET04 lock setting		
9	LOC05	Common parameter setting mode SET05 lock setting		
10	LOC06	Common parameter setting mode SET06 lock setting		
11	LOC07	Common parameter setting mode SET07 lock setting		
12	LOC08	Common parameter setting mode SET08 lock setting		
13	LOC09	Common parameter setting mode SET09 lock setting		
14	LOC10	Common parameter setting mode SET10 lock setting		
15	LOC11	Common parameter setting mode SET11 lock setting		
16	LOC12	Common parameter setting mode SET12 lock setting		
17	LOCS1	Setting temperature (All steps in a batch)		
18	LOCS2	Wait function setting (All steps in a batch)		
19	LOCS3	Time signal 1 function setting (All steps in a batch)		
20	LOCS4	Time signal 2 function setting (All steps in a batch)		
21	LOCS5	Time signal 3 function setting (All steps in a batch)		
22	LOCS6	Time signal 4 function setting (All steps in a batch)		
23	LOCS7	Operation amount limiter function setting (All steps in a batch)		
24	LOCS8	Setting time (All steps in a batch)		
25	LOCS9	Run times		
26	LOCSA	End signal ON time		

	DWG No. 48-7000-F	PAGE 36/72
--	----------------------	---------------

## 6.12 List of the alarm temperature setting mode setting

		Name	Setting content	Initial value
1	<b>E1H</b>	Event 1 upper limit setting	See Section 6.6 "Common parameter setting mode SET 5 to 8."	
2	<b>E1L</b>	Event 1 lower limit setting		
3	<b>E2H</b>	Event 2 upper limit setting		
4	<b>E2L</b>	Event 2 lower limit setting		
5	<b>E3H</b>	Event 3 upper limit setting		
6	<b>E3L</b>	Event 3 lower limit setting		
7	<b>E4H</b>	Event 4 upper limit setting		
8	<b>E4L</b>	Event 4 lower limit setting		

## 6.13 List of the PID setting mode setting

		Name	Setting content	Initial value
1	<b>P1</b>	Proportional band setting for PID No. 1 (low temperature)	See Section 6.5 "Common parameter setting mode SET 4."	
2	<b>I1</b>	Integral time setting for PID No. 1 (low temperature)		
3	<b>D1</b>	Derivative time setting for PID No. 1 (low temperature)		
4	<b>PM1</b>	Intermediate point 1 setting for the PID range		
5	<b>P2</b>	Proportional band setting for PID No. 2 (intermediate temperature)		
6	<b>I2</b>	Integral time setting for PID No. 2 (intermediate temperature)		
7	<b>D2</b>	Derivative time setting for PID No. 2 (intermediate temperature)		
8	<b>PM2</b>	Intermediate point 2 setting for the PID range		
9	<b>P3</b>	Proportional band setting for PID No. 3 (high temperature)		
10	<b>I3</b>	Integral time setting for PID No. 3 (high temperature)		
11	<b>D3</b>	Derivative time setting for PID No. 3 (high temperature)		

## 6.14 Caution

Care must be used for the names with suffixes as described below:

- \*1: Setting related to steps in a run cannot be changed.
- \*2: No change is possible during a run.
- \*3: SAVE (all settings writing) is performed.

## 7. Screen Existence/Nonexistence Conditions

### 7.1 Pattern No. setting and program setting modes

		Name	Screen availability condition
1	<b>SV *</b>	Setting temperature (*1)	
2	<b>W *</b>	Wait function setting (*1)	
3	<b>TS1 *</b>	Time signal 1 function setting (*1)	In the case of existence of the open collector option
4	<b>TS2 *</b>	Time signal 2 function setting (*1)	
5	<b>TS3 *</b>	Time signal 3 function setting (*1)	
6	<b>TS4 *</b>	Time signal 4 function setting (*1)	
7	<b>ML *</b>	Operation amount limiter function setting (*1)	In the case of <b>[MLF = 1]</b> and <b>[CNT = 1, 3 or 4]</b>
8	<b>T *</b>	Setting time (*1)	
9	<b>RNC</b>	running times	
10	<b>E ON</b>	End signal ON time	In the case of existence of the relay contact output B option and <b>[RNES = 1]</b>

### 7.2 Common parameter setting mode SET 1

		Name	Screen availability condition
1	<b>PAT</b>	Number-of-patterns setting	
2	<b>PVSV</b>	PV start/SV start selection	
3	<b>SVSV</b>	Start temperature setting at SV start	In the case of <b>[PVSV = SV]</b>
4	<b>RNES</b>	In-a-run output/end signal output selection	In the case of existence of the relay contact output B option
5	<b>ERUN</b>	External drive signal selection	In case of existence of the DI option
6	<b>TPV</b>	Power outage restoration temperature width setting	

### 7.3 Common parameter setting mode SET 2

		Name	Screen availability condition
1	<b>WZ1</b>	Wait zone 1 setting	
2	<b>WT1</b>	Wait time 1 setting	
3	<b>WZ2</b>	Wait zone 2 setting	
4	<b>WT2</b>	Wait time 2 setting	
5	<b>WZ3</b>	Wait zone 3 setting	
6	<b>WT3</b>	Wait time 3 setting	
7	<b>WZ4</b>	Wait zone 4 setting	
8	<b>WT4</b>	Wait time 4 setting	

### 7.4 Common parameter setting mode SET 3

		Name	Screen availability condition
1	<b>ONT1</b>	Time signal ON delay timer 1	In the case of existence of the open collector option
2	<b>OFT1</b>	Time signal OFF delay timer 1	
3	<b>ONT2</b>	Time signal ON delay timer 2	
4	<b>OFT2</b>	Time signal OFF delay timer 2	
5	<b>ONT3</b>	Time signal ON delay timer 3	
6	<b>OFT3</b>	Time signal OFF delay timer 3	
7	<b>ONT4</b>	Time signal ON delay timer 4	
8	<b>OFT4</b>	Time signal OFF delay timer 4	

	DWG No. 48-7000-F	PAGE 38/72
--	----------------------	---------------

## 7.5 Common parameter setting mode SET 4

	SET04	Name	Screen availability condition
1	SLH	SV limiter upper limit	
2	SLL	SV limiter lower limit	
3	CNT	Control type setting	
4	DIR	Forward/reverse operation setting	
5	MV1	Primary control operating amount	
6	TUN	Tuning type setting	
7	ATG	AT coefficient setting	
8	ATC	AT sensitivity setting	
9	AT1	AT startup screen for PID No. 1 (low temperature)	
10	AT2	AT startup screen for PID No. 2 (intermediate temperature)	
11	AT3	AT startup screen for PID No. 3 (high temperature)	
12	ATALL	AT startup screen for PID No. 1~3	
13	P1	Proportional band setting for PID No. 1 (low temperature)	
14	I1	Integral time setting for PID No. 1 (low temperature)	
15	D1	Derivative time setting for PID No. 1 (low temperature)	
16	PM1	Intermediate point 1 setting for the PID range	In the case of [CNT = 1, 3 or 4]
17	P2	Proportional band setting for PID No. 2 (intermediate temperature)	
18	I2	Integral time setting for PID No. 2 (intermediate temperature)	
19	D2	Derivative time setting for PID No. 2 (intermediate temperature)	
20	PM2	Intermediate point 2 setting for the PID range	
21	P3	Proportional band setting for PID No. 3 (high temperature)	
22	I3	Integral time setting for PID No. 3 (high temperature)	
23	D3	Derivative time setting for PID No. 3 (high temperature)	
24	T1	Primary control proportional cycle	
25	ARW	Anti-reset windup	
26	PS1	Primary control loop abnormality PV variation setting	
27	LOP1	Primary control loop abnormality time setting	
28	CMOD	Primary control off-point position selection setting	In the case of [CNT = 2 or 5]
29	C1	Primary control sensitivity control	
30	CP1	Primary control off-point position	In the case of [CNT = 2 or 5] and [CMOD = 0]
31	MV2	Secondary control operating amount	In the case of [CNT = 3, 4 or 5]
32	PC1	Secondary control proportional band setting for PID No. 1 (low temperature)	
33	PC2	Secondary control proportional band setting for PID No. 2 (intermediate temperature)	In the case of [CNT = 3]
34	PC3	Secondary control proportional band setting for PID No. 3 (high temperature)	
35	T2	Secondary control proportional cycle	
36	PS2	Secondary control loop abnormality PV variation setting	In the case of [CNT = 3, 4 or 5]
37	LOP2	Secondary control loop abnormality time setting	
38	C2	Secondary control sensitivity setting	In the case of [CNT = 4 or 5]
39	CP2	Secondary control off-point position	In the case of [CNT = 4], or in the case of [CNT = 5] and besides [CMOD = 0].
40	PBB	Manual reset	In the case of [CNT = 1, 3 or 4]
41	DB	Dead band	In the case of [CNT = 3, 4 or 5]
42	O1F	Target connection output 1 selection	
43	TRN1	Transmission output function setting	In the case of [O1F = 2]
44	TRh1	Transmission scaling upper limit setting	
45	TRL1	Transmission scaling lower limit setting	In the case of [TRN1 = 0,1]
46	O2F	Target connection setting 2	In the case of existence of the OUT2
47	TRN2	Transmission output function setting	In the case of [O2F = 2]
48	TRh2	Transmission scaling upper limit setting	
49	TRL2	Transmission scaling lower limit setting	In the case of [TRN2 = 0,1]

	DWG No. 48-7000-F	PAGE 39/72
--	----------------------	---------------

## 7.6 Common parameter setting mode SET 5 to 8

	Name	Screen availability condition
	<b>SET05</b> Common parameter setting mode SET 5	In the case of existence of the relay contact output A option.
	<b>SET06</b> Common parameter setting mode SET 6	In case the unit is equipped with Relay Contact Point Output Option A, at the same time the OUT2 Output is other than Relay Output.
	<b>SET07</b> Common parameter setting mode SET 7	In case the unit is equipped with Relay Contact Point Output Option A, at the same time the OUT1 Output is other than Relay Output.
	<b>SET08</b> Common parameter setting mode SET 8	In case the unit is equipped with Open Collector Option, at the same time the OUT1 Output or the OUT2 Output is other than Relay Output.
1	<b>E*F1</b> Event function 1 setting	
2	<b>E*H</b> Event upper limit setting	In case of [ <b>E*F1</b> = *1, *2, *4, *5, *6 or *8]
3	<b>E*L</b> Event lower limit setting	In case of [ <b>E*F1</b> = *1, *3, *4, *5, *7 or *8]
4	<b>E*C</b> Event sensitivity setting	In case of [ <b>E*F1</b> = *1 to *8]
5	<b>E*T</b> Event delay timer setting	In case of [ <b>E*F1</b> = *1 to *8]
6	<b>E*F2</b> Event function 2 setting (loop abnormality)	
7	<b>E*P</b> Event polarity setting	

	DWG No. 48-7000-F	PAGE 40/72
--	----------------------	---------------

## 7.7 Common parameter setting mode SET 9

	SET09	Name	Screen availability condition
1	MLF	Operation amount function setting	In the case of [CNT = 1, 3 or 4]
2	MLH11	Primary control operation amount limiter upper limit 1	In case of [CNT = 1, 3 or 4] and [MLF = 1]
3	MLL11	Primary control operation amount limiter lower limit 1	
4	MLH21	Primary control operation amount limiter upper limit 2	
5	MLL21	Primary control operation amount limiter lower limit 2	
6	MLH31	Primary control operation amount limiter upper limit 3	
7	MLL31	Primary control operation amount limiter lower limit 3	
8	MLH41	Primary control operation amount limiter upper limit 4	
9	MLL41	Primary control operation amount limiter lower limit 4	
10	MLH12	Secondary control operation amount limiter upper limit 1	In case of [CNT = 3] and [MLF = 1]
11	MLL12	Secondary control operation amount limiter lower limit 1	
12	MLH22	Secondary control operation amount limiter upper limit 2	
13	MLL22	Secondary control operation amount limiter lower limit 2	
14	MLH32	Secondary control operation amount limiter upper limit 3	
15	MLL32	Secondary control operation amount limiter lower limit 3	
16	MLH42	Secondary control operation amount limiter upper limit 4	
17	MLL42	Secondary control operation amount limiter lower limit 4	
18	CM1	CT1 current value monitor	In the case of existence of the CT option and [CNT = 1 & MLF = 2,3]
19	OH01	Operation amount limiter point 1	In the case of the OUT2 output being the 4-to-20-mADC current output and CT option, and besides [CNT = 1] and [MLF = 2,3]
20	OH02	Operation amount limiter point 2	
21	OH03	Operation amount limiter point 3	
22	OH04	Operation amount limiter point 4	
23	OH05	Operation amount limiter point 5	
24	OH06	Operation amount limiter point 6	
25	OH07	Operation amount limiter point 7	
26	OH08	Operation amount limiter point 8	
27	OH09	Operation amount limiter point 9	
28	OH10	Operation amount limiter point 10	
29	OH11	Operation amount limiter point 11	
30	AH01	Current value limiter point 1	
31	AH02	Current value limiter point 2	
32	AH03	Current value limiter point 3	
33	AH04	Current value limiter point 4	
34	AH05	Current value limiter point 5	
35	AH06	Current value limiter point 6	
36	AH07	Current value limiter point 7	
37	AH08	Current value limiter point 8	
38	AH09	Current value limiter point 9	
39	AH10	Current value limiter point 10	
40	AH11	Current value limiter point 11	
41	AHC	Current value limiter sensitivity	
42	OU1	Primary control operation amount increase rate	In case of [CNT = 1, 3 or 4]
43	OUTM1	Primary control operation amount increase time	
44	OU2	Secondary control operation amount increase rate	In case of [CNT = 3]
45	OUTM2	Secondary control operation amount increase time	

	DWG No. 48-7000-F	PAGE 41/72
--	----------------------	---------------

### 7.8 Common parameter setting mode SET 10

	SET10	Name	Screen availability condition
1	INP1	Input type setting	
2	FSH1	Scaling upper limit setting	In case of [INP1 = 15 to 20]
3	FSL1	Scaling lower limit setting	
4	PVG1	PV compensation gain setting	
5	PVS1	PV compensation zero setting	
6	PDF1	PV filter setting	
7	PDFS	Special PV filter setting	In case of [INP1 = 6 or 11]
8	DP1	Decimal point position setting	In the case of INP1 being other than 0 to 3, 7 to 9 or 12 to 30

### 7.9 Common parameter setting mode SET 11

	SET11	Name	Screen availability condition
1	BKUP	Backup of a setting value	
2	RESET	Initialization of a setting value	

### 7.10 Common parameter setting mode SET 12

	SET12	Name	Screen availability condition
1	PRT	Communication protocol setting	
2	COM	Communication parameter	
3	BPS	Communication speed setting	
4	ADR	Communication address setting	
5	AWT	Communication response delay time setting	
6	MOD	Communication switchover setting	In the case of PRT being 0
7	SLV	Number-of-sub-controller-connections setting	In the case of existence of the communications option

	DWG No. 48-7000-F	PAGE 42/72
--	----------------------	---------------

### 7.11 Common parameter setting mode SET 13

	SET13	Name	Screen availability condition
1	LOC-1	Normal screen lock setting	
2	LOC-2	Pattern No. setting mode lock setting	
3	LOC-3	Alarm temperature setting mode lock setting	
4	LOC-4	PID setting mode lock setting	
5	LOC01	Common parameter setting mode SET01 lock setting	
6	LOC02	Common parameter setting mode SET02 lock setting	
7	LOC03	Common parameter setting mode SET03 lock setting	In the case of existence of the open collector option
8	LOC04	Common parameter setting mode SET04 lock setting	
9	LOC05	Common parameter setting mode SET05 lock setting	In the case of existence of the relay contact output A option.
10	LOC06	Common parameter setting mode SET06 lock setting	In the case of the OUT2 output being the relay output and besides existence of the relay contact output A option.
11	LOC07	Common parameter setting mode SET07 lock setting	In the case of the OUT1 output being the SSR drive voltage output and besides existence of the relay contact output A option.
12	LOC08	Common parameter setting mode SET08 lock setting	In the case of the OUT1 output or the OUT2 output being the SSR drive voltage output and besides existence of the open collector option.
13	LOC09	Common parameter setting mode SET09 lock setting	In case of [CNT = 1, 3 or 4]
14	LOC10	Common parameter setting mode SET10 lock setting	
15	LOC11	Common parameter setting mode SET11 lock setting	
16	LOC12	Common parameter setting mode SET12 lock setting	
17	LOCS1	Setting temperature (All steps in a batch)	
18	LOCS2	Wait function setting (All steps in a batch)	
19	LOCS3	Time signal 1 function setting (All steps in a batch)	In the case of existence of the open collector option
20	LOCS4	Time signal 2 function setting (All steps in a batch)	
21	LOCS5	Time signal 3 function setting (All steps in a batch)	
22	LOCS6	Time signal 4 function setting (All steps in a batch)	
23	LOCS7	Operation amount limiter function setting (All steps in a batch)	In case of [CNT = 1, 3 or 4] and [MLF = 1]
24	LOCS8	Setting time (All steps in a batch)	
25	LOCS9	Run times	
26	LOCSA	End signal ON time	In the case of existence of the relay contact output B option and [RNES = 1]

## 8. Regarding Various Functions

### 8.1 Program run

Setting items: Number-of-patterns setting: 1 to 15 patterns

Pattern No. setting: 1 to 15 patterns

\* The following number of steps is fixedly set, depending on the number of patterns.

When pattern No. 1 is selected: 99 steps

When pattern No. 2 is selected: 49 steps

When pattern No. 3 is selected: 33 steps

When pattern No. 4 is selected: 24 steps

When pattern No. 5 is selected: 19 steps

When pattern No. 6 is selected: 16 steps

When pattern No. 7 is selected: 14 steps

When pattern No. 8 is selected: 12 steps

When pattern No. 9 is selected: 11 steps

When pattern No. 10 is selected: 9 steps

When pattern No. 11 is selected: 9 steps

When pattern No. 12 is selected: 8 steps

When pattern No. 13 is selected: 7 steps

When pattern No. 14 is selected: 7 steps

When pattern No. 15 is selected: 6 steps

Step temperature: SLL-1 to SLH

Step time: 0 to 99 hours 59 minutes + 1

Run times: 0 - 99 times (0 for infinite number)

Operation description:

To make control, SV is changed parallel to the temperature and time set for each pattern.

If a setting is made to the lower limit within [a setting range - 1] (“- - - -” to be displayed) in the temperature setting for each step, steps following the said step is ineffective and no setting parameter is displayed.

The pattern run ends at one step prior to the step set as “- - - -.”

Neither the step temperature nor the step time in a run can be changed.

If the setting temperature of the step 1 is set at SLL for a PV start, the time of step 1 is effective and a timer run begins. (The normal PV start begins with the step 2.)

“TIME” is displayed in the SV display frame.

If the setting temperature for all steps is 0, setting a temperature for a step results in the next step automatically being set to the same temperature (only at key operation).

If the step time is set above the upper limit within the setting range (“~ ~ ~ ~ ~” to be displayed), the step continuously runs at the setting temperature.

Each pattern repeats for the number of times that has been executed. When the setting is set to “0”, it will continue to repeat until it is stopped with key operation. (max. 9999 times)

During a run, the TIME output is ON.

For display during the program run, see Section 5.3.2 “Auto run (normal mode).”

The following is displayed upon termination of the program.

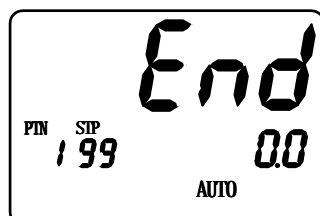

- The screen shown in the left is the normal one. See Section 5.3.2 “Auto run (normal mode)” for the operation amount screen, etc.

## 8.2 Step feed/step return

### Setting items:

External drive signal selection: ON (existence)/OFF (nonexistence)

Step feed: Execution enabled by holding the  $\triangle$  key pressed for 3 seconds on the PV/SV screen in the normal mode.

Step return: Execution enabled by holding the  $\nabla$  key pressed for 3 seconds on the PV/SV screen in the normal mode.

### Operation description:

Holding the " $\triangle$ " key pressed for 3 seconds during a run results in the step feed to transfer to the next step.  
Holding the " $\nabla$ " key pressed for 3 seconds results in the step return to transfer to the step one previous to the current step.

In the case of the external drive signal selection being ON, the step feed is executed when open of the step feed DI changes to closed.

Only the timer is reset when the step return is executed at step 1 (or the leading step).

If the step feed is executed at the step for the endless setting, END is established.

## 8.3 Elapsed time increase/decrease

### Setting items:

Elapsed time (during a step): 0 to step setting time in a run - 1

Elapsed time (during a wait): 0 to step setting time in a run + the wait time - 1

### Operation description:

During a program run, pressing the  $\triangle/\nabla$  key on the elapsed time screen results in an increase/decrease of the elapsed time.

The unit of the elapsed time is minute. Counting the number of seconds continues.

The change range of the elapsed time is 0 to [the setting time in a run - 1].

The change range of the elapsed time for a wait zone is 0 to [the setting time in a run + the wait time - 1].

Execution of an increase/decrease in the wait zone results in an increase/decrease of the elapsed time; however, setting the elapsed time below the setting time results in a return to the normal step run but not to the wait zone.

This function is ineffective for an end signal.

## 8.4 Wait function

### Setting items:

Wait zone 1 to 4: Setting range varies depending on the input type.

Wait time 1 to 4: 0 to 99 hours 59 minutes

Wait function selection (for all steps): 0 to 4 (0 indicates no function.)

### Operation description:

For the current step transferring to the next step, the next step does not begin if PV has not reached the wait zone (similarly, if PV has overreached) after the step time elapsed.

However, if the wait time elapses, the next step begins at that point.

The above operation is executed by selecting 0 to 4 for each step, or by setting value for 1 to 4.

Selecting 0 indicates no function.

In the case of [the wait zone setting = 0], in-a- wait is effective until PV goes beyond SV.

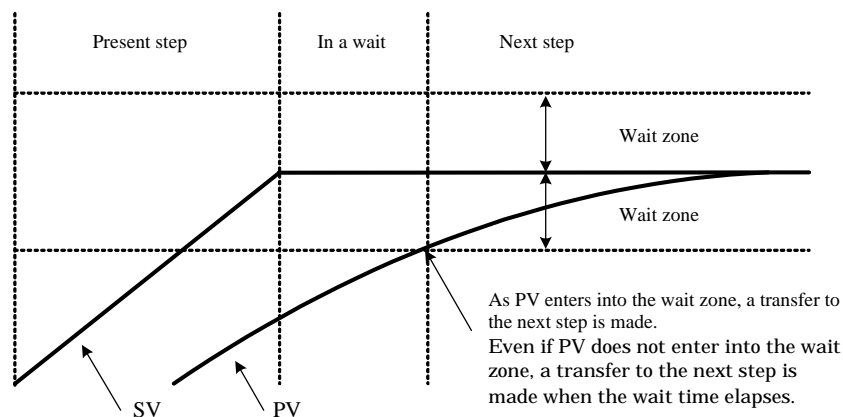

## 8.5 Three-zone PID function

Setting items:

PID range intermediate point 1 setting: SLL to SLH - 5 [°C]

PID range intermediate point 2 setting: Setting value for the intermediate point 1 to SLH

Proportional band setting for PID Nos. 1 to 3 (low to high temperature): 0.1 to 200.0 [%]

Integral time setting for PID Nos. 1 to 3 (low to high temperature): 0 to 3600 [second]

Derivative time setting for PID Nos. 1 to 3 (low to high temperature): 0 to 3600 [second]

Secondary control proportional band setting for PID Nos. 1 to 3 (low to high temperature): 0.10 to 10.00 [times]

Operation description:

Numerical values of P, I, D and PC are switched over at each of the low, intermediate and high temperatures.

The ranges of the three zones are as follows:

- Low temperature (PID No. 1): SLL to intermediate point 1
- Intermediate temperature (PID No. 2): Intermediate point 1 to intermediate point 2
- High temperature (PID No. 3): Intermediate point 2 to SLH

## 8.6 Auto tuning function

Setting items:

AT startup screen of PID No.1 (low temperature): SLL to PID range intermediate point 1 setting

AT startup screen of PID No.2 (intermediate temperature): PID range intermediate point 1 setting to PID range intermediate point 2 setting

AT startup screen of PID No.3 (high temperature): PID range intermediate point 2 setting to SLH

AT startup screen of PID No.1~3 : The setting does not exist.

Operation description:

Auto tuning starts at each of low, intermediate and high temperatures.

Auto tuning starts when the temperature at which the auto tuning is to be performed is set on each startup screen and the RUN/STOP key is pressed or by an Auto tuning start command of the communication.

During the auto tuning, AT-1 (to 3) and SV are alternately displayed in the SV display digit ,and ATALL and PV are alternately displayed in the PV display digit.

Re-pressing the RUN/STOP key results in a stop of the auto tuning.

If the auto tuning has not terminated 3 hours after its start, an AT error is established and the run stops, displaying "ERR2."

Attempting an auto tuning during an automatic run results in first a temporary stop and then start of the auto tuning. During a manual run, the auto tuning is not possible.

## 8.7 PV start/SV start

Setting items:

PV start/SV start selection: PV start/SV start

SV start temperature setting: SLL to SLH

Operation description:

At a start of the program run after selecting the PV start and SV start, the start SV indicates the following:

PV start:

The run starts from the ramp step of upward slope in which the measurement temperature is included.

In addition, the run starts from the elapsed time, of which amount is assumed to elapse to come to the start point.

The calculation is made with the start point of 0°C /0 digit.

For below 0°C /0 digit, the calculation is made with the elapsed time of 0 minute.

SV start: The program run starts from the SV start temperature setting.

	DWG No. 48-7000-F	PAGE 46/72
--	----------------------	---------------

### 8.8 Time signal output

Setting items:

ON delay timers 1 to 4: 0 to 99 hours 59 minutes

OFF delay timers 1 to 4: 0 to 99 hours 59 minutes

Time signals 1 to 4 function selection (for all steps): 0 to 5 (0 indicates no function; 5 does in-a-step ON)

Operation description:

At starting each step, the time signals 1 to 4 are turned on upon elapse of the time set on the ON delay timer.

Then, the output is turned off upon elapse of the time set on the OFF delay timer.

During the time signal output ON, corresponding lamps of TS1 to TS4 light up.

Select the function selection among 0 to 5 of TS 1 to 4 at each step; if either one of 1 to 4 is selected, the above operation is performed with the setting; if 0 is selected, no function is available; if 5 is selected, ON is always set during the selection step.

If the time is set backward by using the  $\Delta$  or  $\nabla$  key, even after elapse of time, the output returns to the one corresponding to the point at which the time set backward and time counting starts at that point, i.e., in the middle of the way.

Example: If the elapsed time is returned by 5 minutes by using the  $\nabla$  key 3 minutes after the OFF delay terminates, the output turns on and the OFF delay counts for 2 minutes.

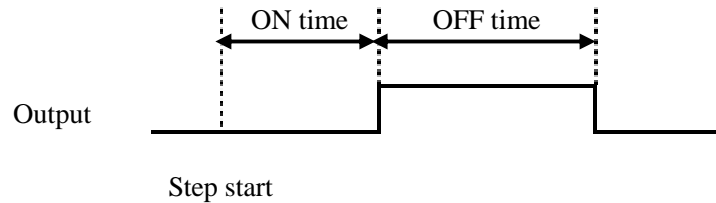

### 8.9 In-a-run signal output/end signal output selection function

Setting items:

In-a-run signal output/end signal output selection: 0 (in-a-run signal output)

1 (end signal output selection)

Operation description:

The use purpose of one relay output is selected from either in-a-run signal output or end signal output.

#### 8.9.1 When selecting the in-a-run signal output

Operation description:

During a run, the relay output is always ON as in-a-run signal output.

#### 8.9.2 When selecting the end signal output

Setting items:

END signal ON time: 0 to 99 hours 59 minutes + 1

Operation description:

At termination of the program run, the output as the end signal output is turned on or off according to the following flow.

If the setting is above the maximum value within the setting range (“~~~~~” to be displayed), the output remains turned on until the reset status described in Section 5.3.1 is established.

Also, the END lamp lights up.

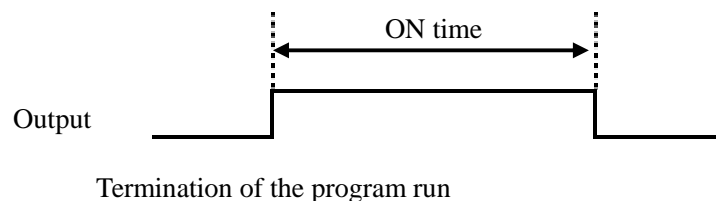

## 8.10 DI (external input)

Setting items:

External drive signal selection: ON (existence)/OFF (nonexistence)

Operation description:

Operation including run can be performed via DI through the external drive signal selection.

For the function of each DI, see Sections 8.10.1 to 8.10.4.

No operation is performed for [external drive signal = OFF].

### 8.10.1 Run/reset DI

Operation description:

The following operation is performed when ON continues for 2 seconds after the external contact open (OFF) changes to the external contact closed (ON):

During a run: The run stops.

During a stop: A run starts.

### 8.10.2 Hold DI

Operation description:

The following operation is performed when ON continues for 2 seconds after the external contact open (OFF) changes to the external contact closed (ON):

During a run: The run stops momentarily.

During a momentary stop: The run restarts.

### 8.10.3 Step feed DI

Operation description:

The step changes when the external contact open (OFF) changes to the external contact closed (ON) during a program run.

### 8.10.4 Patterns 1 to 4 DI

Operation description:

A pattern is selected from 1 to 15, which are configured by combination of the external contacts 1 to 4 closed (ON) and open (OFF).

No switchover of a pattern No. is possible during a run.

If all external contacts 1 to 4 are open (OFF), choose the pattern No. selected in the pattern No. setting mode.

Pattern 1 DI: 1

Pattern 2 DI: 2

Pattern 3 DI: 4

Pattern 4 DI: 8

Example: If both pattern 1DI and pattern 3DI are ON, selected pattern No. is:  $1 + 4 = 5$ .

## 8.11 Auto run (AUTO)/manual run (MANU)

Setting items: Operation amount: 0.0 to 100.0 [%] (settable only for a manual run)

Operation description:

The base of a run is the auto run (AUTO); the auto run, however, changes to the manual run (MANU) by holding the AUTO/MANU key pressed for 3 seconds.

No control is performed during a manual run, but the operation amount is output in a display.

The displayed operation amount is identical to the SV displayed in the lower row on the PV/SV screen in the normal mode.

Pressing the  $\Delta/\nabla$  key in this status results in a change of the operation amount to be output.

The operation amount and step time are as follows at the start of a manual run:

– Operation amount

In the case of in-a-stop: Starts with the operation amount of 0.0%.

In the case of in-a-run: Starts with the operation amount at the time of switchover

– Step time

In the case of in-a-stop: Remains in a stop (no step time counting begins).

In the case of in-a-run: The step time elapses (remains in a stop during a momentary stop).

Re-holding the AUTO/MANU key pressed for 3 seconds results in a return to the auto run.

The AUTO and MANU lamps lights up as follows:

During an auto run: The AUTO lamp turns on and the MANU lamp turns off.

During a manual run: The AUTO lamp turns off and the MANU lamp turns on.

The output interval during a manual run is fixed to 10 seconds.

## 8.12 Operation amount limiter

Setting items: Operation amount function selection

0: No function

1: Operation amount limiter

2: Operation amount current limiter

Operation description:

By using the operation amount function selection, “no limit function” can be set or two types of operation amount limiters can be effective.

In addition, two types of limiters can be effective by using the other operation amounts limiter setting described in Section 8.13.3.

### 8.12.1 Operation amount limiter

Setting items:

Primary/secondary control operation amount upper limiters 1 to 4: Primary/secondary control operation amount lower limiters 1 to 4 to 100.0 [%]

Primary/secondary control operation amount lower limiters 1 to 4: 0.0 to primary/secondary control operation amount upper limiters 1 to 4 [%]

Operation amount limiter function selection (for all steps): 0 to 4 (0 indicates no function)

Operation description:

The operation amount is limited by using the primary/secondary control operation amount upper limiters and Primary/secondary control operation amount lower limiters selected by the operation amount limiter function selection at each step.

If the operation amount limiter function selection is 0, then 0.0 to 100.0 % is applicable.

	DWG No. 48-7000-F	PAGE 49/72
--	----------------------	---------------

### 8.12.2 Operation amount current limiter

Setting items:

Operation amount limiter points 1 to 11: 0.0 to 100.0 [%]

Current value limiter points 1 to 11: 0.0 to 30.0 [A]

Current limiter sensitivity: 0.1 to 40.0 [A]

Operation description:

The operation amount and current value are limited at each point obtained by dividing SLL to SLH into 10.

At the operation amount limiter points 1 to 11, the operation amount resulted from calculation is limited.

At the current value limiter points 1 to 11, the operation amount is limited by the operation amount at the current value limiter point determined from a measured current value and present operation amount if the measured current value at each point exceeds the value [setting value - current limiter sensitivity].

This operation amount changes each time when measuring the current value.

The final operation amount is limited by using either smaller limit of the above two.

The function is effective when [OUT 2 selection = 4 to 20mA], CT existent, [CNT = 1] and operation amount current limiter effective. OUT2 outputs MV1 (equivalent to OUT1).

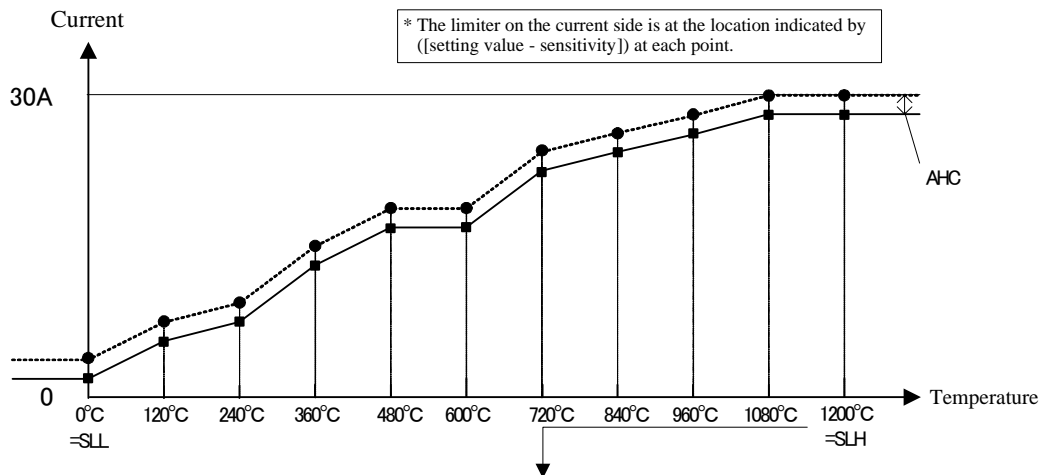
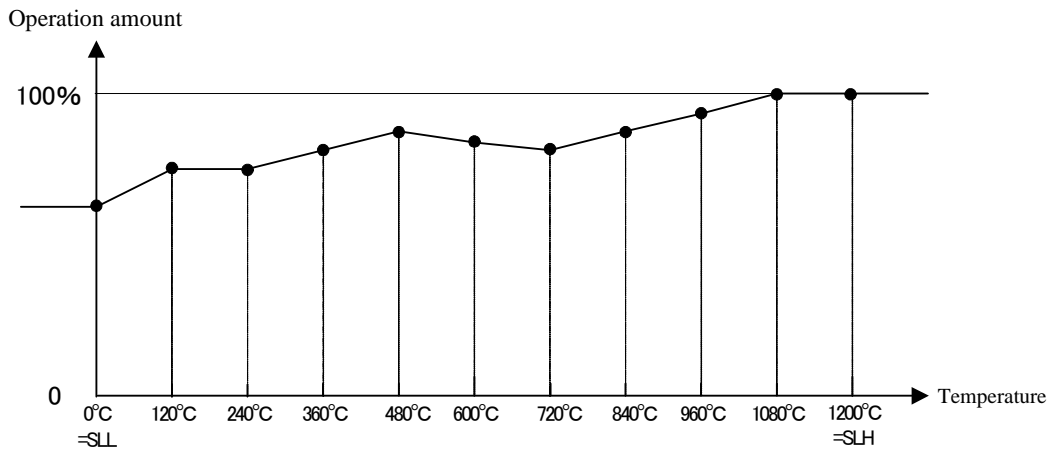

- For an input below the table range, the SLL operation amount and the current value are used for calculation.  
 - For an input above the table range, the SLH operation amount and the current value are used for calculation.

	DWG. No. 48-7000-F	PAGE 50/72
--	-----------------------	---------------

Example:

Assume the following for various settings and PV:

PV = 120 °C, operation amount limiter point 2 = 75.0%, current value limiter point 2 = 10.0 A, present operation amount = 60.0% and AHC = 1.0 A.

– If measured current valued = 15 A:

Based on the relation [0 to present operation amount (60.0%) = 0.0 to measured current value (15.0 A)], the operation amount [current value limiter point 2 (10.0 A) - current limiter sensitivity (1.0 A)] is to be determined.

The calculation results in the operation amount of 36.0%.

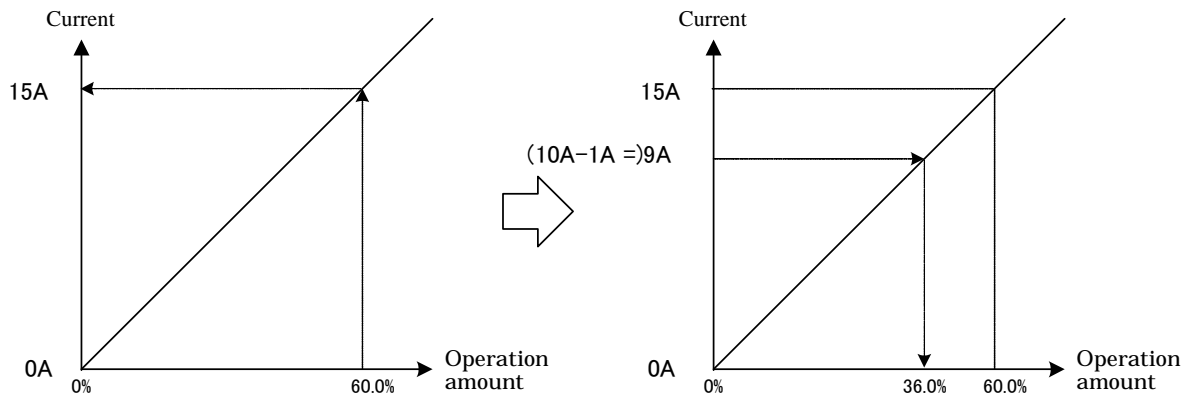

\* The operation limiter point 2 = 75.0%; as this amount is larger than the operation amount resulted from the calculation, the operation amount is eventually limited at 36.0%.

### 8.13.3 Other operation amounts limiter setting

#### 8.13.3-1 Primary/secondary control operation amount change limiter increase setting

Setting items:

Primary/secondary control operation amount change limiter increase setting: 0.0 to 549.9 [%] (no function by setting at 0.0 [%])

Operation description:

The increase rate of variation of a calculated operation amount is limited.

The operation amount allowed to increase for a second is set in percent.

The setting is effective during AT.

If the setting is changed, control results also changes; redo AT.

If the setting is 100%, the variation increases only up to 20 % for input sampling (200 ms).

To increase up to 100% for input sampling (200 ms), set at 500%.

$(1 \text{ second} \div 200 \text{ ms}) \times 100\% = 500\%$

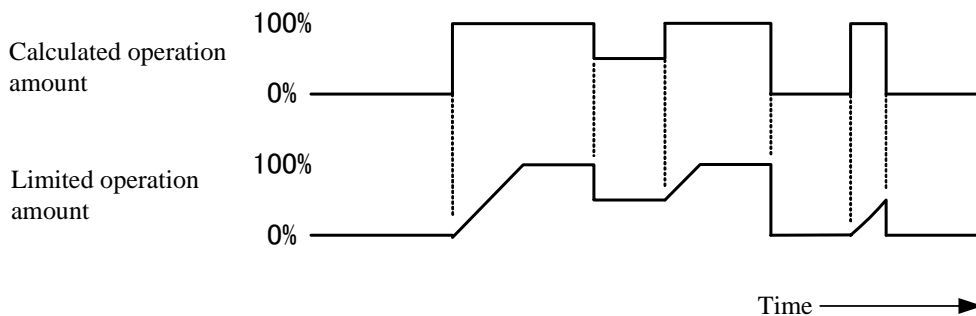

	DWG No. 48-7000-F	PAGE 51/72
--	----------------------	---------------

8.13.3-2 Primary/secondary control operation amount increase time

Setting items:

Primary/secondary control operation amount increase time: 0 to 3600 [second] (no function by setting at 0 [second])

Operation description:

For a remote run, apply a limit on the operation amount such that the ratio of the operation amount to the calculated operation amount is from 0% at the start to 100% at the setting time.

The setting is effective also during AT.

If the setting is changed, control results change; redo the AT.

Operation is performed only at the control start (RDY to RUN or MAN or AT)

Care must be used, as no limit applies by the operation amount increase time after the setting time.

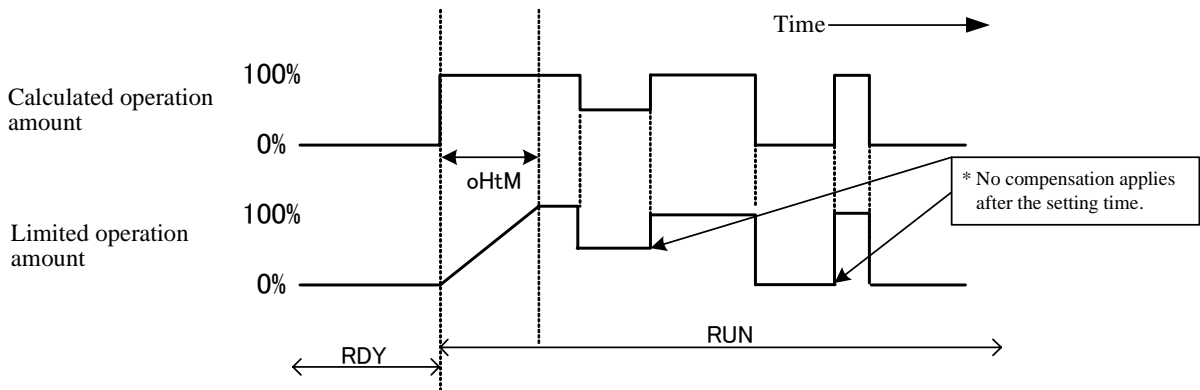
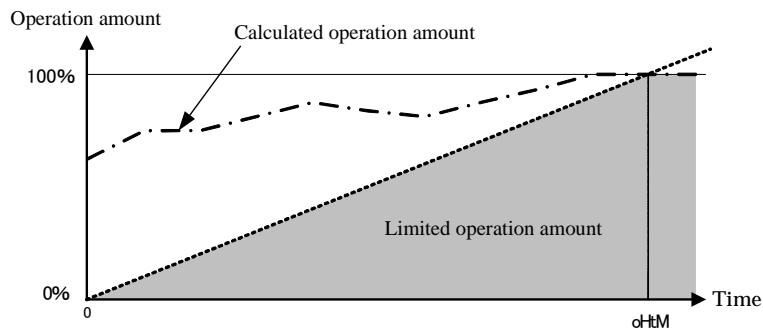

## 8.14 Key lock

Setting item:

Normal screen lock setting	: 0 (lock OFF)/1 (lock ON)
Pattern No. setting mode lock setting	: 0 (lock OFF)/1 (lock ON)
Alarm temperature setting mode lock setting	: 0 (lock OFF)/1 (lock ON)
PID setting mode lock setting	: 0 (lock OFF)/1 (lock ON)
Common parameter setting mode SET 01 to 12 lock setting	: 0 (lock OFF)/1 (lock ON)
Setting temperature (for 99 steps)	: 0 (lock OFF)/1 (lock ON)
Wait function setting (All steps in a batch)	: 0 (lock OFF)/1 (lock ON)
Time signal 1 function setting (All steps in a batch)	: 0 (lock OFF)/1 (lock ON)
Time signal 2 function setting (All steps in a batch)	: 0 (lock OFF)/1 (lock ON)
Time signal 3 function setting (All steps in a batch)	: 0 (lock OFF)/1 (lock ON)
Time signal 4 function setting (All steps in a batch)	: 0 (lock OFF)/1 (lock ON)
Operation amount limiter function setting (All steps in a batch)	: 0 (lock OFF)/1 (lock ON)
Setting time (All steps in a batch)	: 0 (lock OFF)/1 (lock ON)
Run times	: 0 (lock OFF)/1 (lock ON)
End signal ON time	: 0 (lock OFF)/1 (lock ON)

Operation description:

When a change of each parameter is attempted in a lock after lock ON/OFF is elected, "LOC" is displayed in the SV display section.

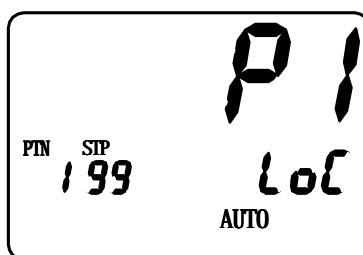

## 8.15 PV filter setting

### 8.15.1-1 PV filter setting

Setting description:

PV filter setting: 0.0 to 99.9 [second]

B thermocouple/PR40-20 special PV filter setting: 0.0 to 99.9 [second]

(No function by setting at 0 [second])

Operation description:

This setting is a function to achieve the CR filter effect on the software by performing a primary delay calculation on the PV of the input 1.

The filter effect is set with the damping time constant [t].

(Damping time constant is defined as time when PV reaches about 63% in a stepwise change of input.)

\* CR filter: Filter of first order lag

Application of a PV filter:

- (1) By elimination of high-frequency noise, effect of noise is mitigated when electric noise applies to input.
- (2) Response can be delayed for an abrupt change of input.

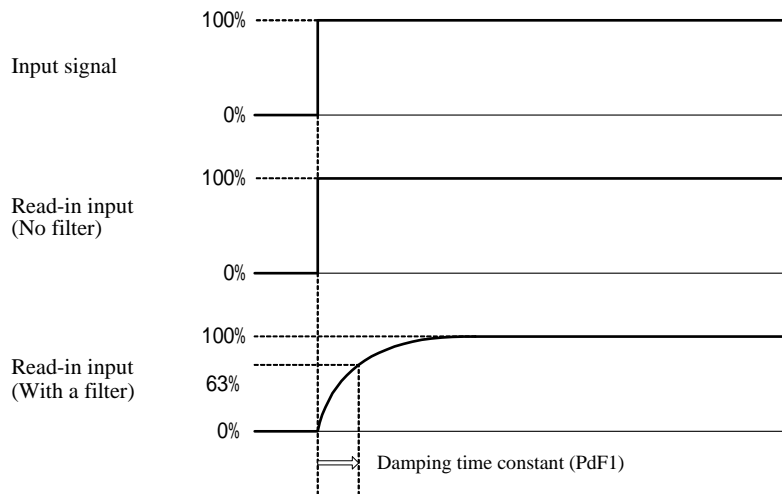

	DWG No. 48-7000-F	PAGE 54/72
--	----------------------	---------------

**8.15.2 B thermocouple/PR40-20 special PV filter setting**

Setting items:

B thermocouple/PR40-20 special PV filter setting: 0.0 to 99.9 [second]  
 (No function by setting at 0 [second])

Operation description:

This setting is a function for the input 1 to add the PV filter setting time further with a limitation of a particular range on the B thermocouple and PR40-20.

Filter effect is set by the damping time constant [t].

The effective range of the set filter is as follows:

- (1) B thermocouple: In the case of 400°C or below
- (2) PR40-20: In the case of below 800°C

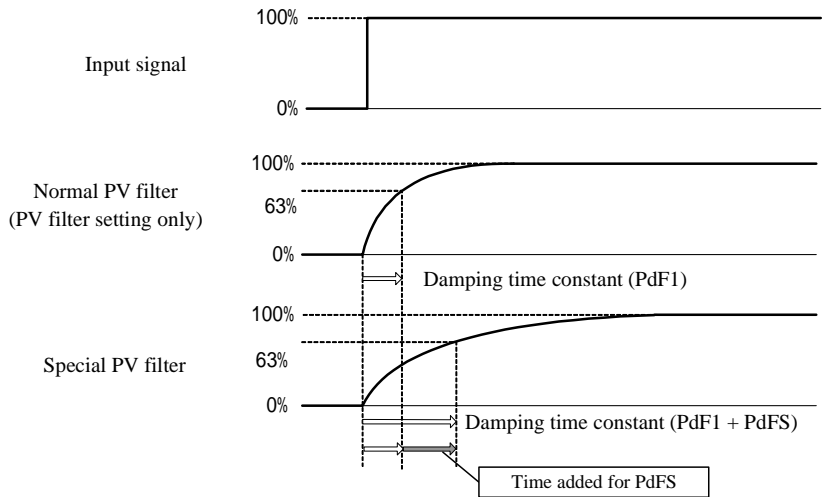

## 8.16 Event alarm

### Setting items:

Events 1 to 4 function 1 setting:

- \*0: None
- \*1: Deviation upper/lower limit alarm
- \*2: Deviation upper limit alarm
- \*3: Deviation lower limit alarm
- \*4: Deviation upper/lower limit range alarm
- \*5: Absolute value upper/lower limit alarm
- \*6: Absolute value upper limit alarm
- \*7: Absolute value lower limit alarm
- \*8: Absolute value upper/lower limit range alarm

– The following is additional functions:

- 0\*: No additional function
- 1\*: Output hold
- 2\*: Standby
- 3\*: Delay
- 4\*: Hold + standby
- 5\*: Hold + Delay
- 6\*: Standby + Delay
- 7\*: Hold + standby + Delay

Events 1 to 4 upper limit setting: The setting range varies, depending on input type.

Events 1 to 4 lower limit setting: The setting range varies, depending on input type.

Events 1 to 4 sensitivity setting: The setting range varies, depending on input type.

Events 1 to 4 Delay setting: 0 to 9999 (second)

Events 1 to 4 function 2 setting (loop abnormality): 0 (nonexistence)/1 (existence); hold possible

Events 1 to 4 polarity setting: 0 (normal open)/1 (normal closed)

### Operation description:

By setting the events 1 to 4 function setting, outputs of AL 1 to 4 are turned on if PV is located within the alarm range.

Corresponding AL1 to AL4 lamps light up.

By switching over the events 1 to 4 polarities, selection of open/closed is possible at the turn-on.

Output is also turned on at occurrence of a loop abnormality when the events 1 to 4 function 2 setting is effective.

\* For loop abnormality, see Section 8.17 “Loop abnormality.”

The setting can be released by using the key or reset DI, provided that the following condition is met:

- (1) Normal status at the release
- (2) Standby existent even if abnormality status at the release

Judgment process is performed only during a run (no judgment made during a stop).

Restoration from a power outage is made for the status previous to the outage.

## 8.17 Loop abnormality

### Setting items:

Primary/secondary control loop abnormality PV change amount setting: The setting range varies, depending on input type.

Primary/secondary control loop abnormality time setting: 0 to 3600 seconds

### Operation description:

When the primary/secondary control loop abnormality PV change amount setting is not 0, the PV change amount is determined every loop abnormality time setting time if the present step is a soak.

Consequently, “loop abnormality” occurs if the following condition is met:  $PV \leq$

Primary/secondary control loop abnormality PV change amount setting.

Function OFF is established if the primary/secondary control loop abnormality PV change amount setting is 0.

## 9. Communications

Two communications methods are available: (1) a personal computer as a parent machine connected to this product (loader communications), which as a parent machine is connected to a child machine of a program controller (child machine communications), or (2) RS-485 communications, where a personal computer as parent is connected to this product.

### 9.1 Loader communications

A personal computer as a parent machine is connected to this product.

For basic operation of communications, see the communications operation manual for TOHO standard products.

For setting values, read/write availability, identifier, etc., see the following pages.

### 9.2 RS-485 communications

Setting items:

Number of connected child machines setting (address): 0 to 10

Operation description:

When the number of connected child machines setting is 1 to 10, the child machine communications described in Section 9.2.1 takes place.

When the number of connected child machines setting is 0, the normal communications described in Section 9.2.2 takes place.

When 0 is set, simultaneous write of the loader and RS-485 sides must be avoided, as either the loader or RS-485 side may become NAK2.

#### 9.2.1 Child machine communications

Fixed items:

Communications protocol: Fixed at TOHO protocol

Communications parameter: b8n2

Communications speed: 19200 BPS

Communications response delay time setting: 0 ms

Operation description:

This product as a parent machine communicates with the program controller as a child machine.

The transmitted child machine address corresponds to the number of child machines setting.

\* If the setting is 3, addresses 1 to 3 are sequentially transmitted.

The child machine is required to match the parent machine in terms of communications setting, input type, SLL, etc.

Communications data is only SV.

During a stop of a run, no transmission takes place.

Upon a start of a run, the SV data is transmitted to the child machine.

After termination of the run, the child machine ends the run by sending data “ END”

Abnormality conditions and operations are as follows:

– Abnormality conditions

In the case that there is no response after data transmission, or there is a NAK response.

– Operation at abnormality

Retry is made 3 times.

If abnormality responses are received 3 consecutive times, “ERR3” is displayed and the parent machine stops the run.

During a parent machine manual run, the SV directly before the switchover to manual is continuously transmitted.

(During a child machine manual run, an ACK response is made to the SV transmission; control is made by the manual value.)

At restoration from a power outage, no SV data is transmitted for a particular time period after the initial display, considering the delayed startup time of the child machine (the time period is to be determined based on actual measurement).

#### 9.2.2 Normal communications

A personal computer as a parent machine is connected to this product.

For the basic operation of communications, see the communications operation manual of TOHO standard products.

The same is applicable for setting values, read/write availability, identifier, etc. as the loader communications described in Section 9.1. (See the following pages.)

	DWG No. 48-7000-F	PAGE 57/72
--	----------------------	---------------

### 9.3 List of communications items

#### 9.3.1 List of Normal mode items

Identifier	modbus		Screen character	Name	Command	Remark
	Absolute (DEC)	Relative (hex)				
PV1	40001	0000		Measured temperature	RLB	HHHHH: Overscale LLLLL: Underscale
SV	40003	0002		Present setting temperature	RLB	At L/B 00000: Displays PV alone 00001: Displays SV alone 00002: PV/SV 00003: PV/TIM 00004: SV/TIM 00005: PV/SV/TIM 00006: PV/1MV·2MV 00007: SV/1MV·2MV 00008: PV/SV/1MV·2MV 00009: PV/TIM/1MV·2MV 00010: SV/TIM/1MV·2MV 00011: PV/SV/TIM/1MV·2MV
TIM	40005	0004		Elapsed time	RLB	
1MV	40007	0006		Primary control operation amount	RLB	
2MV	40013	000C		Secondary control operation amount	RLB	
STP	40009	0008		Present step No.	R	
PA	40011	000A	<b>PATT</b>	Pattern No. setting mode	RWLB	
ALM				Alarm temperature setting mode	LB	
PID				PID setting mode	LB	

#### 9.3.2 List of settings of pattern No. setting and program setting modes

Identifier	modbus		Screen character	Name	Command	Remark
	Absolute (DEC)	Relative (hex)				
SSV	44097 to 44293	1000 to 10C4	<b>SV</b> *	Setting temperature (for 99 steps)	RWLB	At R/W, the second identifier exists. At L/B: 00000: All not displayed 00001: All displayed
SWA	44295 to 44491	10C6 to 118A	<b>W</b> *	Wait function setting (for 99 steps)	RWLB	Ditto
TS1	44493 to 44689	118C to 1250	<b>TS1</b> *	Time signal 1 function setting (for 99 steps)	RWLB	Ditto
TS2	44691 to 44887	1252 to 1316	<b>TS2</b> *	Time signal 2 function setting (for 99 steps)	RWLB	Ditto
TS3	44889 to 45085	1318 to 13DC	<b>TS3</b> *	Time signal 3 function setting (for 99 steps)	RWLB	Ditto
TS4	45087 to 45283	13DE to 14A2	<b>TS4</b> *	Time signal 4 function setting (for 99 steps)	RWLB	Ditto
SML	45285 to 45481	14A4 to 1568	<b>ML</b> *	Operation amount limiter function setting (for 99 steps)	RWLB	Ditto
STI	45483 to 45679	156A to 162E	<b>T</b> *	Setting time (for 99 steps)	RWLB	Ditto
RNC	45683	1632	<b>RNC</b>	Run times	RWLB	Pay attention to MODBUS address.
EON	45681	1630	<b>E ON</b>	End signal ON time	RWLB	

\* For details of the second identifier, see Section 9.4 "Second identifier."

	DWG No. 48-7000-F	PAGE 58/72
--	----------------------	---------------

### 9.3.3 Common parameter setting mode SET 1

toho Identifier	modbus		Screen character	Name	Command	Remark
	Absolute (DEC)	Relative (hex)				
PAT	40257	0100	<b>PAT</b>	Number-of-patterns setting	RWLB	
PS	40259	0102	<b>PVSV</b>	PV start/SV start selection	RWLB	
SS	40261	0104	<b>SVSV</b>	Start temperature setting at SV start	RWLB	
RE	40263	0106	<b>RNES</b>	In-a-run output/end signal output selection	RWLB	
ERN	40265	0108	<b>ERUN</b>	External drive signal selection	RWLB	
TPV	40267	010A	<b>TPV</b>	Power outage restoration temperature width setting	RWLB	

### 9.3.4 Common parameter setting mode SET 2

toho Identifier	modbus		Screen character	Name	Command	Remark
	Absolute (DEC)	Relative (hex)				
WZ1	40513	0200	<b>WZ1</b>	Wait zone 1 setting	RWLB	
WT1	40515	0202	<b>WT1</b>	Wait time 1 setting	RWLB	
WZ2	40517	0204	<b>WZ2</b>	Wait zone 2 setting	RWLB	
WT2	40519	0206	<b>WT2</b>	Wait time 2 setting	RWLB	
WZ3	40521	0208	<b>WZ3</b>	Wait zone 3 setting	RWLB	
WT3	40523	020A	<b>WT3</b>	Wait time 3 setting	RWLB	
WZ4	40525	020C	<b>WZ4</b>	Wait zone 4 setting	RWLB	
WT4	40527	020E	<b>WT4</b>	Wait time 4 setting	RWLB	

### 9.3.5 Common parameter setting mode SET 3

toho Identifier	modbus		Screen character	Name	Command	Remark
	Absolute (DEC)	Relative (hex)				
ON1	40769	0300	<b>ONT1</b>	Time signal ON delay timer 1	RWLB	
OF1	40771	0302	<b>OFT1</b>	Time signal OFF delay timer 1	RWLB	
ON2	40773	0304	<b>ONT2</b>	Time signal ON delay timer 2	RWLB	
OF2	40775	0306	<b>OFT2</b>	Time signal OFF delay timer 2	RWLB	
ON3	40777	0308	<b>ONT3</b>	Time signal ON delay timer 3	RWLB	
OF3	40779	030A	<b>OFT3</b>	Time signal OFF delay timer 3	RWLB	
ON4	40781	030C	<b>ONT4</b>	Time signal ON delay timer 4	RWLB	
OF4	40783	030E	<b>OFT4</b>	Time signal OFF delay timer 4	RWLB	

	DWG No. 48-7000-F	PAGE 59/72
--	----------------------	---------------

### 9.3.6 Common parameter setting mode SET 4

Identifier	modbus		Screen character	Name	Command	Remark
	Absolute (DEC)	Relative (hex)				
SLH	41025	0400	SLH	SV limiter upper limit	RWLB	
SLL	41027	0402	SLL	SV limiter lower limit	RWLB	
CNT	41029	0404	CNT	Control type setting	RWLB	
DIR	41031	0406	DIR	Forward/reverse operation setting	RWLB	
MV1	41033	0408	MV1	Primary control operating amount	RWLB	
TUN	41115	045A	TUN	Tuning type setting	RWLB	Pay attention to MODBUS address.
ATG	41117	045C	ATG	AT coefficient setting	RWLB	Pay attention to MODBUS address.
ATC	41119	045E	ATC	AT sensitivity setting	RWLB	Pay attention to MODBUS address.
AT1	41035	040A	AT1	AT startup screen for PID No. 1 (low temperature)	RWLB	
AT2	41037	040C	AT2	AT startup screen for PID No. 2 (intermediate temperature)	RWLB	
AT3	41039	040E	AT3	AT startup screen for PID No. 3 (high temperature)	RWLB	
AT			ATALL	AT startup screen for PID No. 1~3	LB	
P1	41041	0410	P1	Proportional band setting for PID No. 1 (low temperature)	RWLB	
I1	41043	0412	I1	Integral time setting for PID No. 1 (low temperature)	RWLB	
D1	41045	0414	D1	Derivative time setting for PID No. 1 (low temperature)	RWLB	
PM1	41047	0416	PM1	Intermediate point 1 setting for the PID range	RWLB	
P2	41049	0418	P2	Proportional band setting for PID No. 2 (intermediate temperature)	RWLB	
I2	41051	041A	I2	Integral time setting for PID No. 2 (intermediate temperature)	RWLB	
D2	41053	041C	D2	Derivative time setting for PID No. 2 (intermediate temperature)	RWLB	
PM2	41055	041E	PM2	Intermediate point 2 setting for the PID range	RWLB	
P3	41057	0420	P3	Proportional band setting for PID No. 3 (high temperature)	RWLB	
I3	41059	0422	I3	Integral time setting for PID No. 3 (high temperature)	RWLB	
D3	41061	0424	D3	Derivative time setting for PID No. 3 (high temperature)	RWLB	
T1	41063	0426	T1	Primary control proportional cycle	RWLB	
ARW	41065	0428	ARW	Anti-reset windup	RWLB	
1PS	41067	042A	PS1	Primary control loop abnormality PV variation setting	RWLB	
LP1	41069	042C	LOP1	Primary control loop abnormality time setting	RWLB	
CMD	41071	042E	CMOD	Primary control off-point position selection setting	RWLB	
CC1	41073	0430	C1	Primary control sensitivity control	RWLB	
CP1	41075	0432	CP1	Primary control off-point position	RWLB	
MV2	41079	0436	MV2	Secondary control operating amount	RWLB	
PC1	41081	0438	PC1	Secondary control proportional band setting for PID No. 1 (low temperature)	RWLB	
PC2	41083	043A	PC2	Secondary control proportional band setting for PID No. 2 (intermediate temperature)	RWLB	
PC3	41085	043C	PC3	Secondary control proportional band setting for PID No. 3 (high temperature)	RWLB	
T2	41087	043E	T2	Secondary control proportional cycle	RWLB	
2PS	41089	0440	PS2	Secondary control loop abnormality PV variation setting	RWLB	
LP2	41091	0442	LOP2	Secondary control loop abnormality time setting	RWLB	
CC2	41093	0444	C2	Secondary control sensitivity setting	RWLB	
CP2	41095	0446	CP2	Secondary control off-point position	RWLB	
PBB	41077	0434	PBB	Manual reset	RWLB	
DB	41097	0448	DB	Dead band	RWLB	
O1F	41099	044A	O1F	Target connection output 1 selection	RWLB	
TR1	41101	044C	TRN1	Transmission output function setting	RWLB	
TH1	41103	044E	TRH1	Transmission scaling upper limit setting	RWLB	
TL1	41105	0450	TRL1	Transmission scaling lower limit setting	RWLB	
O2F	41107	0452	O2F	Target connection output 2 selection	RWLB	
TR2	41109	0454	TRN2	Transmission output function setting	RWLB	
TH2	41111	0456	TRH2	Transmission scaling upper limit setting	RWLB	
TL2	41113	0458	TRL2	Transmission scaling lower limit setting	RWLB	

	DWG No. 48-7000-F	PAGE 60/72
--	----------------------	---------------

### 9.3.7 Common parameter setting mode SET 5

Identifier	modbus		Screen character	Name	Command	Remark
	Absolute (DEC)	Relative (hex)				
E1I	41281	0500	<b>E1F1</b>	Out1 event function 1 setting	RWLB	
E1H	41283	0502	<b>E1H</b>	Out1 event upper limit setting	RWLB	
E1L	41285	0504	<b>E1L</b>	Out1 event lower limit setting	RWLB	
E1C	41287	0506	<b>E1C</b>	Out1 event sensitivity setting	RWLB	
E1T	41293	050C	<b>E1T</b>	Out1 event delay timer	RWLB	Pay attention to MODBUS address.
E12	41289	0508	<b>E1F2</b>	Out1 event function 2 setting	RWLB	
E1P	41291	050A	<b>E1P</b>	Out1 event polarity setting	RWLB	

### 9.3.8 Common parameter setting mode SET 6

Identifier	modbus		Screen character	Name	Command	Remark
	Absolute (DEC)	Relative (hex)				
E2I	41537	0600	<b>E2F1</b>	Out2 event function 1 setting	RWLB	
E2H	41539	0602	<b>E2H</b>	Out2 event upper limit setting	RWLB	
E2L	41541	0604	<b>E2L</b>	Out2 event lower limit setting	RWLB	
E2C	41543	0606	<b>E2C</b>	Out2 event sensitivity setting	RWLB	
E2T	41549	060C	<b>E2T</b>	Out2 event delay timer	RWLB	Pay attention to MODBUS address.
E22	41545	0608	<b>E2F2</b>	Out2 event function 2 setting	RWLB	
E2P	41547	060A	<b>E2P</b>	Out2 event polarity setting	RWLB	

### 9.3.9 Common parameter setting mode SET 7

Identifier	modbus		Screen character	Name	Command	Remark
	Absolute (DEC)	Relative (hex)				
E3I	41793	0700	<b>E3F1</b>	Out3 event function 1 setting	RWLB	
E3H	41795	0702	<b>E3H</b>	Out3 event upper limit setting	RWLB	
E3L	41797	0704	<b>E3L</b>	Out3 event lower limit setting	RWLB	
E3C	41799	0706	<b>E3C</b>	Out3 event sensitivity setting	RWLB	
E3T	41805	070C	<b>E3T</b>	Out3 event delay timer	RWLB	Pay attention to MODBUS address.
E32	41801	0708	<b>E3F2</b>	Out3 event function 2 setting	RWLB	
E3P	41803	070A	<b>E3P</b>	Out3 event polarity setting	RWLB	

### 9.3.10 Common parameter setting mode SET 8

Identifier	modbus		Screen character	Name	Command	Remark
	Absolute (DEC)	Relative (hex)				
E4I	42049	0800	<b>E4F1</b>	Out4 event function 1 setting	RWLB	
E4H	42051	0802	<b>E4H</b>	Out4 event upper limit setting	RWLB	
E4L	42053	0804	<b>E4L</b>	Out4 event lower limit setting	RWLB	
E4C	42055	0806	<b>E4C</b>	Out4 event sensitivity setting	RWLB	
E4T	42061	080C	<b>E4T</b>	Out4 event delay timer	RWLB	Pay attention to MODBUS address.
E42	42057	0808	<b>E4F2</b>	Out4 event function 2 setting	RWLB	
E4P	42059	080A	<b>E4P</b>	Out4 event polarity setting	RWLB	

## 9.3.11 Common parameter setting mode SET 9 (1)

Identifier	modbus		Screen character	Name	Command	Remark
	Absolute (DEC)	Relative (hex)				
MLF	42305	0900	<b>MLF</b>	Operation amount function setting	RWLB	
MH1	42307	0902	<b>MLH11</b>	Primary control operation amount limiter upper limit 1	RWLB	
ML1	42309	0904	<b>MLL11</b>	Primary control operation amount limiter lower limit 1	RWLB	
MH2	42311	0906	<b>MLH21</b>	Primary control operation amount limiter upper limit 2	RWLB	
ML2	42313	0908	<b>MLL21</b>	Primary control operation amount limiter lower limit 2	RWLB	
MH3	42315	090A	<b>MLH31</b>	Primary control operation amount limiter upper limit 3	RWLB	
ML3	42317	090C	<b>MLL31</b>	Primary control operation amount limiter lower limit 3	RWLB	
MH4	42319	090E	<b>MLH41</b>	Primary control operation amount limiter upper limit 4	RWLB	
ML4	42321	0910	<b>MLL41</b>	Primary control operation amount limiter lower limit 4	RWLB	
MH5	42377	0948	<b>MLH12</b>	Secondary control operation amount limiter upper limit 1	RWLB	
ML5	42379	094A	<b>MLL12</b>	Secondary control operation amount limiter lower limit 1	RWLB	
MH6	42381	094C	<b>MLH22</b>	Secondary control operation amount limiter upper limit 2	RWLB	
ML6	42383	094E	<b>MLL22</b>	Secondary control operation amount limiter lower limit 2	RWLB	
MH7	42385	0950	<b>MLH32</b>	Secondary control operation amount limiter upper limit 3	RWLB	
ML7	42387	0952	<b>MLL32</b>	Secondary control operation amount limiter lower limit 3	RWLB	
MH8	42389	0954	<b>MLH42</b>	Secondary control operation amount limiter upper limit 4	RWLB	
ML8	42391	0956	<b>MLL42</b>	Secondary control operation amount limiter lower limit 4	RWLB	
CM1	42323	0912	<b>CM1</b>	CT1 current value monitor	RLB	HHHHH: Overscale
OH1	42325	0914	<b>OH01</b>	Operation amount limiter point 1	RWLB	
OH2	42327	0916	<b>OH02</b>	Operation amount limiter point 2	RWLB	
OH3	42329	0918	<b>OH03</b>	Operation amount limiter point 3	RWLB	
OH4	42331	091A	<b>OH04</b>	Operation amount limiter point 4	RWLB	
OH5	42333	091C	<b>OH05</b>	Operation amount limiter point 5	RWLB	
OH6	42335	091E	<b>OH06</b>	Operation amount limiter point 6	RWLB	
OH7	42337	0920	<b>OH07</b>	Operation amount limiter point 7	RWLB	
OH8	42339	0922	<b>OH08</b>	Operation amount limiter point 8	RWLB	
OH9	42341	0924	<b>OH09</b>	Operation amount limiter point 9	RWLB	
OHA	42343	0926	<b>OH10</b>	Operation amount limiter point 10	RWLB	
OHB	42345	0928	<b>OH11</b>	Operation amount limiter point 11	RWLB	
AH1	42349	092C	<b>AH01</b>	Current value limiter point 1	RWLB	
AH2	42351	092E	<b>AH02</b>	Current value limiter point 2	RWLB	
AH3	42353	0930	<b>AH03</b>	Current value limiter point 3	RWLB	
AH4	42355	0932	<b>AH04</b>	Current value limiter point 4	RWLB	
AH5	42357	0934	<b>AH05</b>	Current value limiter point 5	RWLB	
AH6	42359	0936	<b>AH06</b>	Current value limiter point 6	RWLB	
AH7	42361	0938	<b>AH07</b>	Current value limiter point 7	RWLB	
AH8	42363	093A	<b>AH08</b>	Current value limiter point 8	RWLB	
AH9	42365	093C	<b>AH09</b>	Current value limiter point 9	RWLB	
AHA	42367	093E	<b>AH10</b>	Current value limiter point 10	RWLB	
AHB	42369	0940	<b>AH11</b>	Current value limiter point 11	RWLB	
AHC	42371	0942	<b>AHC</b>	Current value limiter sensitivity	RWLB	
OU1	42373	0944	<b>OU1</b>	Primary control operation amount increase rate	RWLB	
OTM	42375	0946	<b>OUTM1</b>	Primary control operation amount increase time	RWLB	
OU2	42393	0958	<b>OU2</b>	Secondary control operation amount increase rate	RWLB	
OT2	42395	095A	<b>OUTM2</b>	Secondary control operation amount increase time	RWLB	

	DWG No. 48-7000-F	PAGE 62/72
--	----------------------	---------------

### 9.3.12 Common parameter setting mode SET 10

toho Identifier	modbus		Screen character	Name	Command	Remark
	Absolute (DEC)	Relative (hex)				
INP	42561	0A00	<b>INP1</b>	Input type setting	RWLB	
FSH	42563	0A02	<b>FSH1</b>	Scaling upper limit setting	RWLB	
FSL	42565	0A04	<b>FSL1</b>	Scaling lower limit setting	RWLB	
PVG	42567	0A06	<b>PVG1</b>	PV compensation gain setting	RWLB	
PVS	42569	0A08	<b>PVS1</b>	PV compensation zero setting	RWLB	
PDF	42571	0A0A	<b>PDF1</b>	PV filter setting	RWLB	
PDS	42573	0A0C	<b>PDS1</b>	Special PV filter setting	RWLB	
DP	42575	0A0E	<b>DP1</b>	Decimal point position setting	RWLB	00000 : 0 00001 : 0.0 00002 : 0.00 00003 : 0.000 00004 : 0.0000

### 9.3.13 Common parameter setting mode SET 11

toho Identifier	modbus		Screen character	Name	Command	Remark
	Absolute (DEC)	Relative (hex)				
BKU			<b>BKUP</b>	Backup of a setting value	LB	
RES			<b>RESET</b>	Initialization of a setting value	LB	

### 9.3.14 Common parameter setting mode SET 12

toho Identifier	modbus		Screen character	Name	Command	Remark
	Absolute (DEC)	Relative (hex)				
PRT	43073	0C00	<b>PRT</b>	Communication protocol setting	RWLB	
COM	43075	0C02	<b>COM</b>	Communication parameter	RWLB	Read/write communication parameter settings Example: B8N2
BPS	43077	0C04	<b>BPS</b>	Communication speed setting	RWLB	00024 : 2400bps 00048 : 4800bps 00096 : 9600bps 00192 : 19200bps 00384 : 38400bps
ADR	43079	0C06	<b>ADR</b>	Communication address setting	RWLB	
AWT	43081	0C08	<b>AWT</b>	Communication response delay time setting	RWLB	
MOD	43083	0C0A	<b>MOD</b>	Communication switchover setting	RWLB	
SLV	43085	0C0C	<b>SLV</b>	Number-of-sub-controller-connections setting	RWLB	

	DWG No. 48-7000-F	PAGE 63/72
--	----------------------	---------------

### 9.3.15 Common parameter setting mode SET 13

Identifier	modbus		Screen character	Name	Command	Remark
	Absolute (DEC)	Relative (hex)				
LM1	43329	0D00	<b>LOC-1</b>	Normal screen lock setting	RWLB	
LM2	43331	0D02	<b>LOC-2</b>	Pattern No. setting mode lock setting	RWLB	
LM3	43333	0D04	<b>LOC-3</b>	Alarm temperature setting mode lock setting	RWLB	
LM4	43335	0D06	<b>LOC-4</b>	PID setting mode lock setting	RWLB	
LC1	43337	0D08	<b>LOC01</b>	Common parameter setting mode SET01 lock setting	RWLB	
LC2	43339	0D0A	<b>LOC02</b>	Common parameter setting mode SET02 lock setting	RWLB	
LC3	43341	0D0C	<b>LOC03</b>	Common parameter setting mode SET03 lock setting	RWLB	
LC4	43343	0D0E	<b>LOC04</b>	Common parameter setting mode SET04 lock setting	RWLB	
LC5	43345	0D10	<b>LOC05</b>	Common parameter setting mode SET05 lock setting	RWLB	
LC6	43347	0D12	<b>LOC06</b>	Common parameter setting mode SET06 lock setting	RWLB	
LC7	43349	0D14	<b>LOC07</b>	Common parameter setting mode SET07 lock setting	RWLB	
LC8	43351	0D16	<b>LOC08</b>	Common parameter setting mode SET08 lock setting	RWLB	
LC9	43353	0D18	<b>LOC09</b>	Common parameter setting mode SET09 lock setting	RWLB	
LCA	43355	0D1A	<b>LOC10</b>	Common parameter setting mode SET10 lock setting	RWLB	
LCB	43357	0D1C	<b>LOC11</b>	Common parameter setting mode SET11 lock setting	RWLB	
LCC	43359	0D1E	<b>LOC12</b>	Common parameter setting mode SET12 lock setting	RWLB	
LS1	43361	0D20	<b>LOCS1</b>	Setting temperature (All steps in a batch)	RWLB	
LS2	43363	0D22	<b>LOCS2</b>	Wait function setting (All steps in a batch)	RWLB	
LS3	43365	0D24	<b>LOCS3</b>	Time signal 1 function setting (All steps in a batch)	RWLB	
LS4	43367	0D26	<b>LOCS4</b>	Time signal 2 function setting (All steps in a batch)	RWLB	
LS5	43369	0D28	<b>LOCS5</b>	Time signal 3 function setting (All steps in a batch)	RWLB	
LS6	43371	0D2A	<b>LOCS6</b>	Time signal 4 function setting (All steps in a batch)	RWLB	
LS7	43373	0D2C	<b>LOCS7</b>	Operation amount limiter function setting (All steps in a batch)	RWLB	
LS8	43375	0D2E	<b>LOCS8</b>	Setting time (All steps in a batch)	RWLB	
LS9	43377	0D30	<b>LOCS9</b>	Run times	RWLB	
LSA	43379	0D32	<b>LOCSA</b>	End signal ON time	RWLB	

	DWG No. 48-7000-F	PAGE 64/72
--	----------------------	---------------

**9.3.16 Others(1)**

toho Identifier	modbus		Screen character	Name	Command	Remark
	Absolute (DEC)	Relative (hex)				
OM1	48193	2000		Output monitor 1	R	00000         +-- Event output 1   +--- Event output 2  +---- Event output 3 +----- Event output 4
OM2	48195	2002		Output monitor 2	R	00000         +-- Time signal output 1   +--- Time signal output 2  +---- Time signal output 3 +----- Time signal output 4
OM3	48197	2004		Output monitor 3	R	00000         +-- Time output   +--- Primary control output  +---- In-a-run/   end signal output +----- Secondary control output
EM1	48199	2006		DI monitor 1	R	00000         +-- Pattern selection 1DI   +--- Pattern selection 2DI  +---- Pattern selection 3DI +----- Pattern selection 4DI
EM2	48201	2008		DI monitor 2	R	00000       +-- Run/stop DI  +--- Hold DI +---- Step feed DI
STR	48207	200A		Store command	W	
MMD	48205	200C		MODE change	RW	R/W of the Mode 00000 : Reset Mode 00001 : Run Mode 00002 : Pause Mode 00003 : Reset Mode during manual operation 00004 : Operation Mode during manual operation 00005 : Pause Mode during manual operation 00006 : During AT, shifting to each mode with "write" is possible, but limited to shifting by key operation only. Also, 0006 is not possible to write.
ADV	48207	200E		Step feed / return	W	00001 : Step feed 00002 : Step return

	DWG No. 48-7000-F	PAGE 65/72
--	----------------------	---------------

### 9.3.16 Others(2)

Identifier	modbus		Screen character	Name	Command	Remark
	Absolute (DEC)	Relative (hex)				
AP1	48209	2010		AT Boot Command for PID NO.1 (low temp.)	W	00001:start 00000:stop
AP2	48211	2012		AT Boot Command for PID NO.2 (medium temp.)	W	00001:start 00000:stop
AP3	48213	2014		AT Boot Command for PID NO.3 (medium temp.)	W	00001:start 00000:stop
AP4	48215	2016		AT Boot Command for PID NO.1-3	W	00001:start 00000:stop
ATR	48219	201A		Auto-Tuning while in execution	R	Read of Auto-Tuning while in execution Unexecuted : 00000 「Low Temp.」: 00001 「Mid Temp.」: 00002 「High Temp.」: 00003
RNR	48221	201C		Run times counter	R	Run times of pattern during operation
001				Common parameter setting mode SET 01 (dedicated for blind)	LB	
002				Common parameter setting mode SET 02 (dedicated for blind)	LB	
003				Common parameter setting mode SET 03 (dedicated for blind)	LB	
004				Common parameter setting mode SET 04 (dedicated for blind)	LB	
005				Common parameter setting mode SET 05 (dedicated for blind)	LB	
006				Common parameter setting mode SET 06 (dedicated for blind)	LB	
007				Common parameter setting mode SET 07 (dedicated for blind)	LB	
008				Common parameter setting mode SET 08 (dedicated for blind)	LB	
009				Common parameter setting mode SET 09 (dedicated for blind)	LB	
010				Common parameter setting mode SET 10 (dedicated for blind)	LB	
011				Common parameter setting mode SET 11 (dedicated for blind)	LB	
012				Common parameter setting mode SET 12 (dedicated for blind)	LB	
013				Common parameter setting mode SET 13 (dedicated for blind)	LB	





	DWG No. 48-7000-F	PAGE 68/72
--	----------------------	---------------

<Composition of the Second Identifier Communication Data Response Message >

The Response Message of the Second Identifier Communication Data will be responded without the Second Identifier.

- Response message in response to a read request message

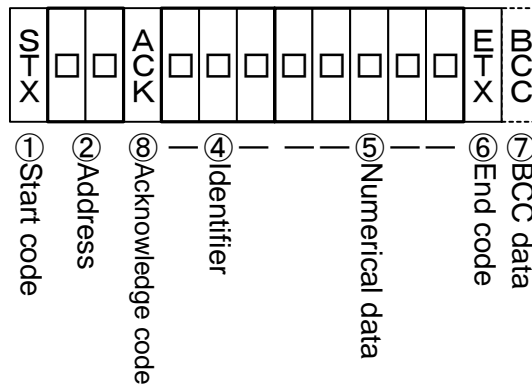

- Response message in response to a write/store request message

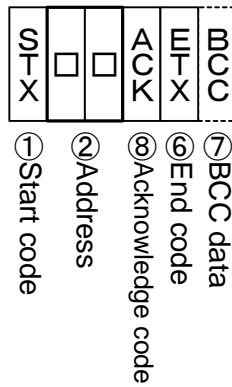

- Response message in the case of an error

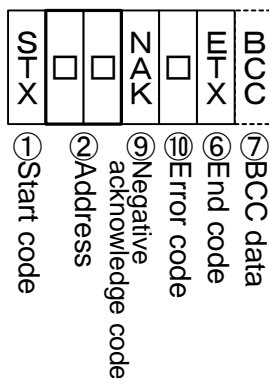

	DWG. No. 48-7000-F	PAGE 69/72
--	-----------------------	---------------

### 10. Blind Function

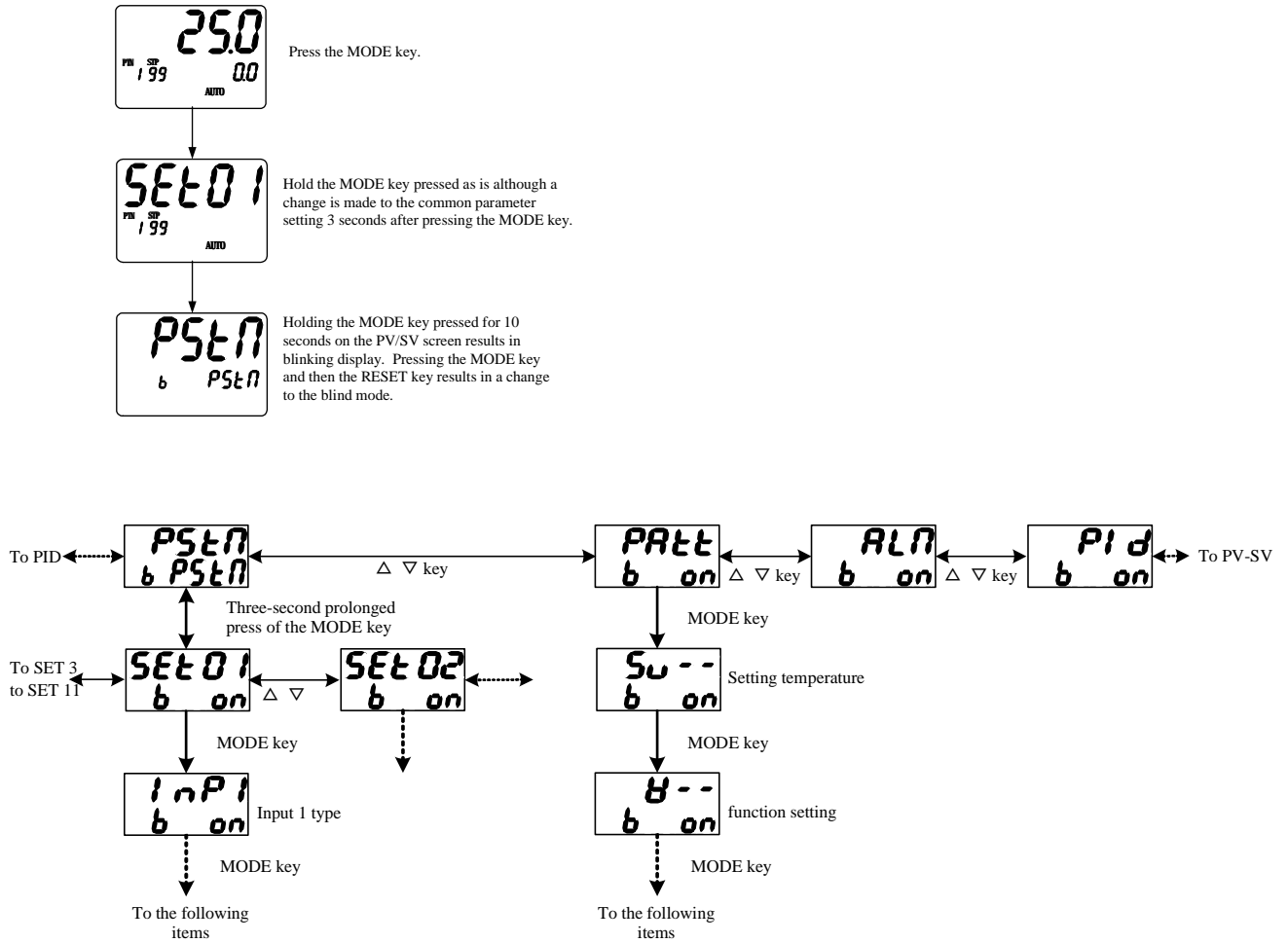

- Holding the MODE key pressed for 10 seconds on the PV/SV screen results in the blind mode.
- In the blind mode, “ON” and “OFF” are displayed in the lower row for each character (SV display section). “ON” indicates display and “OFF” indicates no display (blind). Note that a batch setting applies for the PV/SV screen, elapsed time screen and operation amount screen.
- For a character change in the blind mode, use the DSP.CHG key.
- To terminate the blind setting mode, either turn off the power or hold the MODE key pressed for 10 seconds on the PV/SV screen.
- For blind items, see “L/B” in the column of “Command” in Section 9.3 “List of communications items.”





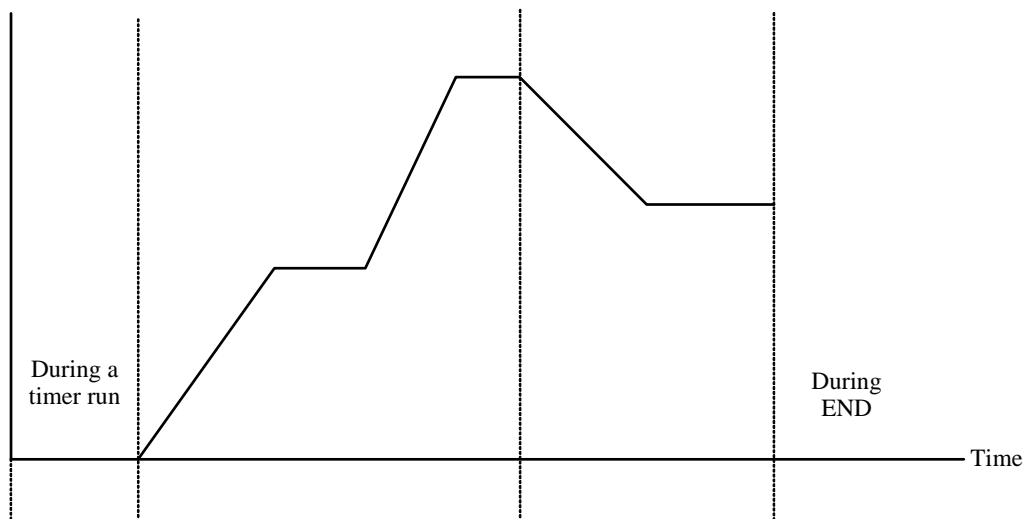

## 11. Electric Power Outage Function

- Upon recovery of the electric power after its outage during a run, the status at the time of the outage is restored under the following conditions. Note that, if the PV at restoration is out of the range of  $[PV \pm \text{electric power outage restoration temperature width}]$ , the restoration is made as a stop.
  - Alarm statuses of the event function are also restored.
- 1) If the step 1 is in the status of a timer run (SV=SLL):  
→ Restored at the location at the time of the outage.
  - 2) In the case of in-a-ramp of SV increase or in-a-soak:  
→ Restored with the PV start.  
Restored with the run end “END” if no SV present.
  - 3) In the case of in-a-ramp of a SV decrease or in-a-soak after the decrease:  
→ Restored with the PV start at the step of the decrease if  $PV > \text{decrease point}$ .  
Restored with the run end “END” if  $PV \leq \text{decrease point}$ .
  - 4) In the case of in-“END”:  
→ Restored to “END.”
  - 5) Restored with a temporary stop for the items 1 through 3 if a power outage occurs during a temporary stop.
  - 6) In the case of in-a-manual-run:  
→ Restored with a stop status.



## 12 Error Names, Display, and Occurrence Conditions/Release Method

Display methods, etc. as follows are used at an abnormality.  
The PV digit turns to red at occurrence of an abnormality.

Name	Display	Occurrence conditions/Release method
Memory error	 * The lower row turns off.	Occurrence condition: Occurs if the recorded setting value is abnormal. Release method: Repair the board.
Temperature input circuit error	 * The lower row turns off.	Occurrence condition: Occurs if the temperature input circuit is abnormal. Release method: Repair the board.
Auto tuning error	 * The lower row turns off.	Occurrence condition: Occurs if the temperature sensor disconnected or the temperature input is out of the display range, or an auto tuning does not end after 3 hours elapsed from its start. Release method: Use either key for release.
Child machine communications error	 * The lower row turns off.	Occurrence condition: Occurs if communications with the child machine is abnormal. Release method: Use the RESET key for recovery.
FRAM error	 * The lower row turns off.	Occurrence condition: Occurs if FRAM (memory element) is abnormal. Release method: Use either key for release. Repair the substrate if re-occurs.
Temperature input upper limit error		Occurrence condition: Occurs if the temperature sensor disconnected or the temperature input is beyond the display range upper limit. Release method: Check the temperature sensor connection; restored if the temperature input returns to within the normal range.
Temperature input lower limit error		Occurrence condition: Occurs if the temperature input is below the display range lower limit. Release method: Check the temperature sensor connection; restored if the temperature input returns to within the normal range.

	DWG No. 48-7000-F	PAGE 72/72
--	----------------------	---------------

### 13. Model

T T M - 3 3 9 - \_ \_ - \_ \_ \_ \_ \_

Symbol	Item	Description
	Size	96 x 96
	Input	Multi-input: Thermocouple, resistance temperature detector, voltage and current
	OUT1 (Primary control)	R Relay contact output
		P SSR drive voltage output (0 to 12 VDC)
		I Current 4 to 20 mADC output
	OUT2 (Primary/secondary control)	N None
		R Relay contact output
		P SSR drive voltage output (0 to 12 VDC)
		I Current 4 to 20 mADC output
	Option	A Relay contact outputs EV1 to EV3 *1
		B Relay contact output END signal output
		C Open collector outputs TS1 to 4, TIME, EV4 output *2
		D CT input *3
		E No-voltage contact input
		M Communications RS-485
		T English version panel sheet

\*1 No EV3 if a relay contact output is selected for OUT1.

\*2 No EV4 if a relay contact output is selected for OUT1.

\*3 Select I for OUT1 or OUT2. This CT is of a type to limit the operation amount but not to detect disconnection. It is effective only for the PID control of the heat control.