

---

# Operation flows and Parameter Description

---



Model: TRM-006A Series  
 Designation: Digital Indicator  
 Job number: K175

APPROVED	APPROVED	CHECKED	DESIGNED	DATE May 17, 2006	Job. No. K175	TITLE Operation flows and Parameter Description	
				MODEL TRM-006A Series		DWG. No.	PAGE
				<b>TOHO ELECTRONICS INC.</b>		46-7635-C	1/16

	DWG No. 46-7635-C	PAGE 2/16
--	----------------------	--------------

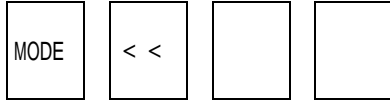
### 1. Description of operation keys

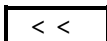

Operation key	Description
MODE key 	<ul style="list-style-type: none"> <li>Used to switch between screens. (Causes the system to store set parameters.)</li> </ul>
DIGITAL MOVE key 	<ul style="list-style-type: none"> <li>Used for moving the digit for each setting. (Selected digit to be displayed in blinks; effective for all modes)</li> </ul>
DOWN key 	<ul style="list-style-type: none"> <li>Used to reduce a setting. (Holding it down 1s to 10s inclusive: 1 digit/100ms) (Holding it down 10s to 20s inclusive: 10 digits/100ms) (Holding it down more than 20s: 100 digits/100ms)</li> </ul>
UP key 	<ul style="list-style-type: none"> <li>Used to increase a setting. (Holding it down 1s to 10s inclusive: 1 digit/100ms) (Holding it down 10s to 20s inclusive: 10 digits/100ms) (Holding it down more than 20s: 100 digits/100ms)</li> </ul>

### 2. Operation flow

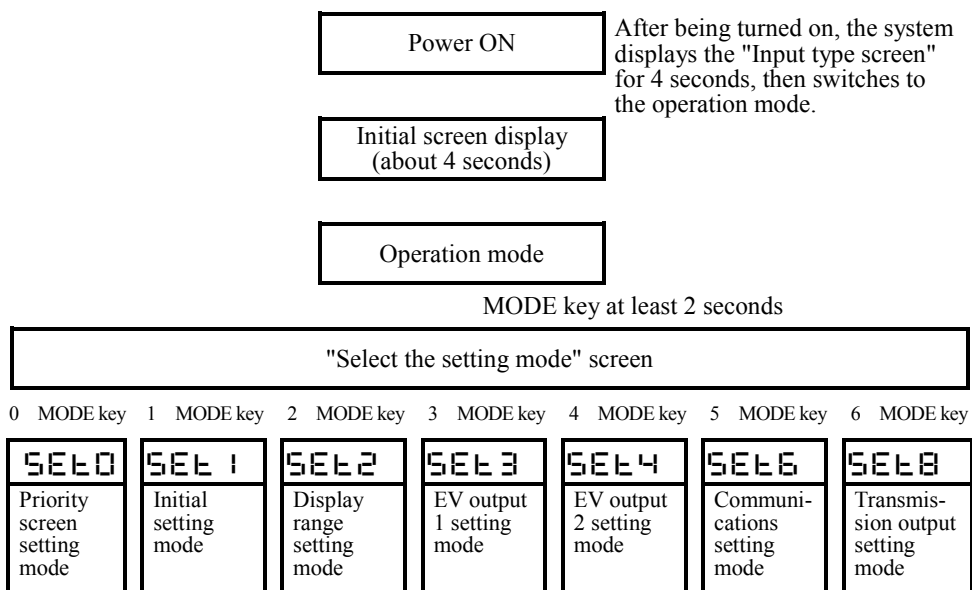

To switch from a specific parameter mode to the "Operation mode" screen, press the MODE key for at least 2 seconds. Leaving the system in a parameter mode for 2 minutes returns it to the operation mode.

	DWG No. 46-7635-C	PAGE 3/16
--	----------------------	--------------

## 2.1 Operation mode

PV  1. PV display  
\* No display in the lower half of the screen (red 7 seg LED)

MODE key

PV  2. PV bottom hold value\*1

MODE key

PV  3. PV peak hold value\*2

MODE key

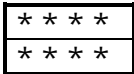
PV  4. First priority screen\*3

MODE key

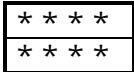
PV  5. Second priority screen\*3

MODE key

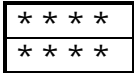
PV  6. Third priority screen\*3

MODE key

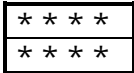
PV  7. Fourth priority screen\*3

MODE key

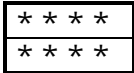
PV  8. Fifth priority screen\*3

MODE key

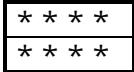
PV  9. Sixth priority screen\*3

MODE key

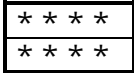
PV  10. Seventh priority screen\*3

MODE key

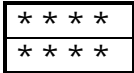
PV  11. Eighth priority screen\*3

MODE key

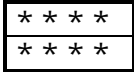
PV  12. Ninth priority screen\*3

MODE key

Back to 1.

\*1: No display when the bottom hold or peak/bottom hold is not set in the PV hold function setting

\*2: No display when the peak hold or peak/bottom hold is not set in the PV hold function setting

\*3: No.1 through No. 9 priority screens display parameters set in the priority screen setting mode.

## 2.2 Priority screen setting mode

PV  1. "Select the setting mode" screen

MODE key

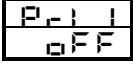
PV  2. Priority screen function setting 1

MODE key

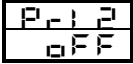
PV  3. Priority screen function setting 2

MODE key

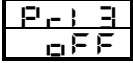
PV  4. Priority screen function setting 3

MODE key

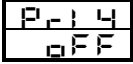
PV  5. Priority screen function setting 4

MODE key

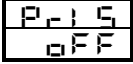
PV  6. Priority screen function setting 5

MODE key

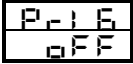
PV  7. Priority screen function setting 6

MODE key

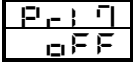
PV  8. Priority screen function setting 7

MODE key

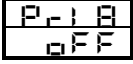
PV  9. Priority screen function setting 8



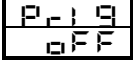

MODE key

PV  10. Priority screen function setting 9

MODE key

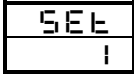
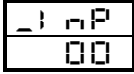
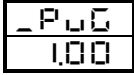
Back to 1.

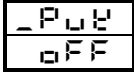
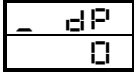
## 2.3 Initial setting mode

- PV  1. "Select the setting mode" screen  
MODE key
- PV  2. Set an input type  
MODE key
- PV  3. Set a PV corrected gain  
MODE key
- PV  4. Set a PV corrected zero point  
MODE key
- PV  5. Set an input filter  
MODE key
- PV  6. Set a PV hold function  
MODE key
- PV  7. Set a decimal place  
MODE key
- PV  8. Set key lock  
MODE key  
Back to 1.

## 2.4 Display range setting mode

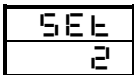
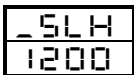
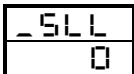
- PV  1. "Select the setting mode" screen\*4  
MODE key
- PV  2. Set a scaling upper limit\*4  
MODE key
- PV  3. Set a scaling lower limit\*4  
MODE key  
Back to 1.

\*4: No display on the models of temperature inputs (inputs from thermocouple/resistance bulb)

## 2.5 Event output 1 (AL1) setting mode

- PV 1. "Select the setting mode" screen  
 MODE key
- PV 2. Set the PV event output 1 function  
 MODE key
- PV 3. Set an upper limit for event output 1 \*5 \*6  
 MODE key
- PV 4. Set a lower limit for event output 1 \*5 \*7  
 MODE key
- PV 5. Set an event output 1 sensitivity \*5  
 MODE key
- PV 6. Set a delay timer for event output 1 \*8  
 MODE key
- PV 7. Set the output 1 function for a special event  
 MODE key
- PV 8. Set a polarity for event output 1  
 MODE key  
 Back to 1.

\*5: Not displayed when the measurement (PV) event output function is not used.

\*6: Not displayed when the measurement (PV) event output is not used in an upper limit alarm.

\*7: Not displayed when the measurement (PV) event output is not used in a lower limit alarm.

\*8: Not displayed when the measurement (PV) event output function/special event output is not used.

## 2.6 Event output 2 (AL2) setting mode

- PV 

SEL
4

 1. "Select the setting mode" screen \*9  
MODE key
- PV 

E2F
00

 2. Set the PV event output 2 function \*9  
MODE key
- PV 

E2H
0

 3. Set an upper limit for event output 2 \*9 \*10 \*11  
MODE key
- PV 

E2L
0

 4. Set a lower limit for event output 2 \*9 \*10 \*12  
MODE key
- PV 

E2C
0

 5. Set an event output 2 sensitivity \*9 \*10  
MODE key
- PV 

E2t
0

 6. Set a delay timer for event output 2 \*9 \*13  
MODE key
- PV 

E2b
00

 7. Set the output 2 function for a special event \*9  
MODE key
- PV 

E2P
0

 8. Set a polarity for event output 2 \*9  
MODE key  
Back to 1.

\*9: Not displayed if event output 2 is not type-specified or if event 2 is not assigned to the output.







\*10: Not displayed if event output 2 is not type-specified, or if event 2 is not assigned to the output, or if the measurement (PV) event output function is not used.

\*11: Not displayed if event output 2 is not type-specified, or if event 2 is not assigned to the output, or if the measurement (PV) event output is not used for the upper limit alarm.

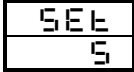
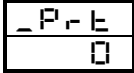
\*12: Not displayed if event output 2 is not type-specified, or if event 2 is not assigned to the output, or if the measurement (PV) event output is not used for the lower limit alarm.

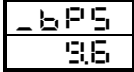
\*13: Not displayed if event output 2 is not type-specified, or if event 2 is not assigned to the output, or if the measurement (PV) event output function/special event output is not used.

## 2.7 Communications setting mode

- PV  1. "Select the setting mode" screen \*14  
 MODE key
- PV  2. Set a communications protocol \*14  
 MODE key
- PV  3. Set a communications parameter \*14  
 MODE key
- PV  4. Set a communications speed \*14  
 MODE key
- PV  5. Set a communications address \*14  
 MODE key
- PV  6. Set a response delay \*14  
 MODE key
- PV  7. Set communications mode switchover \*14  
 MODE key  
 Back to 1.

\*14: Not displayed if the communication (special-purpose protocol, MODBUS) is not type-specified.

## 2.8 Transmission output setting mode

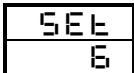
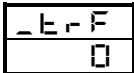
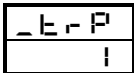
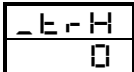
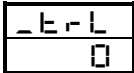
- PV  1. "Select the setting mode" screen \*15  
 MODE key
- PV  2. Set a transmission output function \*15  
 MODE key
- PV  3. Set forward/reverse action switchover for transmission output \*15 \*16  
 MODE key
- PV  4. Set a scaling upper limit for transmission output \*15 \*16  
 MODE key
- PV  5. Set a scaling lower limit for transmission output \*15\*16  
 MODE key  
 Back to 1.

\*15: Not displayed if the transmission output is not type-specified.

\*16: Not displayed if "None" is selected in the transmission output function setting

### 3. Parameter description

#### 3.1 Operation mode

	Character	Designation	Description	Initial value
		Operation mode	Displays measured values and information selected in the priority screen	
1		PV display	Setting unit: °C (model of inputs from thermocouple and resistance bulb) digit (model of inputs from current and voltage) No display in the lower half of the screen (red 7 seg LED)	
2	P r 1	PV bottom hold value	Displays the bottom value Push and hold the “▲” (UP) key to reset the bottom value. * Regarding the hold value: Make sure to reset the bottom hold value whenever setting is changed for inputs. (Input type, PV compensation, decimal point location, scaling upper/lower limit)	PV value since power turn-on
3	P r 1 r	PV peak hold value	Displays the peak value Push and hold the “▲” (UP) key to reset the peak value. * Regarding the hold value: Make sure to reset the bottom hold value whenever setting is changed for inputs. (Input type, PV compensation, decimal point location, scaling upper/lower limit)	PV value since power turn-on
4 5 6 7 8 9 10 11 12		Priority screens 1 to 9	Displays the screen specified in the priority screen setting.	

#### 3.2 Priority screen setting mode

	Character	Designation	Description	Initial value
1	P r 1 P	“Select the setting mode” screen Priority screen setting mode	Setting concerning priority screens	
2 3 4 5 6 7 8 9 10	P r 1 1 P r 1 1 P r 1 1 P r 1 1 P r 1 1 P r 1 1 P r 1 1 P r 1 1 P r 1 1	Set priority screens 1 to 9	Sets a parameter to be displayed in the priority screen.	Screen 1 to 9 E r L

	DWG No. 46-7635-C	PAGE 10/16
--	----------------------	---------------

### 3.3 Initial setting mode

	Character	Designation	Description	Initial value																																						
1	P_r   P	"Select the setting mode" screen Setup mode	Setting concerning inputs and other factors																																							
2	P_r	Set an input type	<div style="border: 1px solid black; padding: 2px; width: fit-content; margin-bottom: 10px;">P_r    </div> <p>Model with thermocouple and resistance bulb</p> <table border="1" style="width: 100%; border-collapse: collapse;"> <thead> <tr> <th></th> <th>Input type</th> </tr> </thead> <tbody> <tr><td>P_r</td><td>Thermocouple K</td></tr> <tr><td>P_r</td><td>Thermocouple J</td></tr> <tr><td>P_r</td><td>Thermocouple R</td></tr> <tr><td>P_r</td><td>Thermocouple T</td></tr> <tr><td>P_r</td><td>Thermocouple N</td></tr> <tr><td>P_r</td><td>Thermocouple S</td></tr> <tr><td>P_r</td><td>Thermocouple B</td></tr> <tr><td>P_r</td><td>Pt100</td></tr> <tr><td>P_r</td><td>JPt100</td></tr> </tbody> </table> <p>Model with current and voltage</p> <table border="1" style="width: 100%; border-collapse: collapse;"> <thead> <tr> <th></th> <th>Input type</th> <th></th> </tr> </thead> <tbody> <tr> <td>P_r</td> <td>0 to 5 VDC</td> <td rowspan="2">←Unavailable with input type change</td> </tr> <tr> <td>P_r</td> <td>1 to 5 VDC</td> </tr> <tr> <td>P_r</td> <td>4 to 20mA DC</td> <td rowspan="2">←Unavailable with input type change</td> </tr> <tr> <td>P_r</td> <td>0 to 1 VDC</td> </tr> <tr> <td>P_r</td> <td>0 to 10 VDC</td> <td rowspan="2">←Unavailable with input type change</td> </tr> <tr> <td>P_r</td> <td>0 to 10mV DC</td> </tr> </tbody> </table>		Input type	P_r	Thermocouple K	P_r	Thermocouple J	P_r	Thermocouple R	P_r	Thermocouple T	P_r	Thermocouple N	P_r	Thermocouple S	P_r	Thermocouple B	P_r	Pt100	P_r	JPt100		Input type		P_r	0 to 5 VDC	←Unavailable with input type change	P_r	1 to 5 VDC	P_r	4 to 20mA DC	←Unavailable with input type change	P_r	0 to 1 VDC	P_r	0 to 10 VDC	←Unavailable with input type change	P_r	0 to 10mV DC	P_r
	Input type																																									
P_r	Thermocouple K																																									
P_r	Thermocouple J																																									
P_r	Thermocouple R																																									
P_r	Thermocouple T																																									
P_r	Thermocouple N																																									
P_r	Thermocouple S																																									
P_r	Thermocouple B																																									
P_r	Pt100																																									
P_r	JPt100																																									
	Input type																																									
P_r	0 to 5 VDC	←Unavailable with input type change																																								
P_r	1 to 5 VDC																																									
P_r	4 to 20mA DC	←Unavailable with input type change																																								
P_r	0 to 1 VDC																																									
P_r	0 to 10 VDC	←Unavailable with input type change																																								
P_r	0 to 10mV DC																																									
3	P_r	Set a PV corrected gain	Setting range: 0.50 to 2.00 times	P_r																																						
4	P_r	Set a PV corrected zero point	<p>Model with thermocouple and resistance bulb Setting range: -199 to 999°C or -199.9 to 999.9°C</p> <p>Model with current and voltage Setting range: -1999 to 9999 digits (decimal place at a specified position)</p>	P																																						
5	P_r	Set the input filter	Setting range: 0 to 99 seconds																																							

	DWG No. 46-7635-C	PAGE 11/16
--	----------------------	---------------

	Character	Designation	Description	Initial value												
6	P r P r	Set a PV hold function	Function type <table border="1"> <tr> <td>P r P</td> <td>No hold</td> </tr> <tr> <td>P r P r</td> <td>Peak hold</td> </tr> <tr> <td>P r P</td> <td>Bottom hold</td> </tr> <tr> <td>P r P r</td> <td>Peak/bottom hold</td> </tr> </table>	P r P	No hold	P r P r	Peak hold	P r P	Bottom hold	P r P r	Peak/bottom hold	P r P				
P r P	No hold															
P r P r	Peak hold															
P r P	Bottom hold															
P r P r	Peak/bottom hold															
7	P P r	Position the decimal point	Model with thermocouple and resistance bulb <table border="1"> <tr> <td>P</td> <td>Disable</td> </tr> <tr> <td>PP</td> <td>Enable</td> </tr> </table> <hr/> Model with current and voltage <table border="1"> <tr> <td>P</td> <td>Disable</td> </tr> <tr> <td>PP</td> <td>1 digit</td> </tr> <tr> <td>PPP</td> <td>2 digits</td> </tr> <tr> <td>PPPP</td> <td>3 digits</td> </tr> </table>	P	Disable	PP	Enable	P	Disable	PP	1 digit	PPP	2 digits	PPPP	3 digits	P
P	Disable															
PP	Enable															
P	Disable															
PP	1 digit															
PPP	2 digits															
PPPP	3 digits															
8	P r P r	Set the key lock	<table border="1"> <tr> <td>P</td> <td>OFF</td> </tr> <tr> <td>P</td> <td>Locks all</td> </tr> <tr> <td>P</td> <td>Locks the operation mode</td> </tr> <tr> <td>P</td> <td>Locks all but the operation mode</td> </tr> </table>	P	OFF	P	Locks all	P	Locks the operation mode	P	Locks all but the operation mode	P				
P	OFF															
P	Locks all															
P	Locks the operation mode															
P	Locks all but the operation mode															

### 3.4 Display range setting mode

	Character	Designation	Description	Initial value
1	r r r r r	Display range setting mode screen	Setting regarding display scaling	
2	r r r r	Set a scaling upper limit	Model with current and voltage Setting range: -1999 to 9999 (decimal place at a specified position) Provided that there shall be a difference of at least 50 digits from the lower limit. Setting range: digit * No setting allowed for the models of thermocouple/resistance bulb	r r r r
3	r r r r	Set a scaling lower limit	Model with current and voltage Setting range: -1999 to 9999 (decimal place at a specified position) Provided that there shall be a difference of at least 50 digits from the upper limit. Setting range: digit * No setting allowed for the models of thermocouple/resistance bulb	r r r r

	DWG No. 46-7635-C	PAGE 12/16
--	----------------------	---------------

### 3.5 Event output Setting mode

	Character	Designation	Description	Initial value																							
1	- - - - -	"Select the setting mode" screen Event output 1 Event output 2	Setting concerning the event output 1 function Setting concerning the event output 2 function																								
2	- E H	Event output Function setting (PV event)	<table border="1" style="margin-bottom: 10px;"> <tr> <td>- E H</td> </tr> </table> <p>PV event function</p> <table border="1" style="margin-bottom: 10px;"> <thead> <tr> <th></th> <th>Type</th> </tr> </thead> <tbody> <tr> <td>-</td> <td>Disable</td> </tr> <tr> <td>-</td> <td>Upper/lower limit</td> </tr> <tr> <td>-</td> <td>Upper limit</td> </tr> <tr> <td>-</td> <td>Lower limit</td> </tr> <tr> <td>-</td> <td>Range</td> </tr> </tbody> </table> <p>Additional function</p> <table border="1"> <thead> <tr> <th></th> <th>Type</th> </tr> </thead> <tbody> <tr> <td>-</td> <td>Disable</td> </tr> <tr> <td>-</td> <td>Hold</td> </tr> <tr> <td>-</td> <td>Standby sequence</td> </tr> <tr> <td>-</td> <td>Hold + standby sequence</td> </tr> </tbody> </table>	- E H		Type	-	Disable	-	Upper/lower limit	-	Upper limit	-	Lower limit	-	Range		Type	-	Disable	-	Hold	-	Standby sequence	-	Hold + standby sequence	- -
- E H																											
	Type																										
-	Disable																										
-	Upper/lower limit																										
-	Upper limit																										
-	Lower limit																										
-	Range																										
	Type																										
-	Disable																										
-	Hold																										
-	Standby sequence																										
-	Hold + standby sequence																										
3 4	- E H - E H	Event output Upper limit setting Event output Lower limit setting	<p>Model with thermocouple and resistance bulb inputs Setting range: -199.9 to 999.9 or -1999 to 9999 Setting unit: °C</p> <hr/> <p>Model with current and voltage inputs Setting range: -1999 to 9999 (decimal place at a specified position) Setting unit: digit</p>	-																							
5	- E H	Event output Sensitivity setting	<p>Model with thermocouple and resistance bulb inputs Setting range: 0.0 to 999.9 0 to 9999 Setting unit: °C</p> <hr/> <p>Model with current and voltage inputs Setting range: 0 to 9999 (decimal place at a specified position) Setting unit: digit</p>	-																							
6	- E H	Event output Delay timer setting	Setting range: 0 to 9999 seconds	-																							

	DWG No. 46-7635-C	PAGE 13/16
--	----------------------	---------------

	Character	Designation	Description	Initial value																
7	_ E H	Event output function (special)	<table border="1" style="margin-bottom: 10px;"> <tr> <td style="width: 10px;">_ E H</td> <td></td> </tr> <tr> <td> </td> <td> </td> </tr> </table> <table border="1" style="margin-bottom: 10px;"> <tr> <td></td> <td style="text-align: center;">Type</td> </tr> <tr> <td style="text-align: center;">-</td> <td>Disable</td> </tr> <tr> <td style="text-align: center;">-</td> <td>PV error</td> </tr> </table> <p>Additional function</p> <table border="1"> <tr> <td></td> <td style="text-align: center;">Type</td> </tr> <tr> <td style="text-align: center;">-</td> <td>Disable</td> </tr> <tr> <td style="text-align: center;">-</td> <td>Hold</td> </tr> </table>	_ E H					Type	-	Disable	-	PV error		Type	-	Disable	-	Hold	--
_ E H																				
	Type																			
-	Disable																			
-	PV error																			
	Type																			
-	Disable																			
-	Hold																			
8	_ E H	Event output Polarity setting	<table border="1" style="margin-bottom: 10px;"> <tr> <td style="width: 10px;">_ E H</td> <td></td> </tr> <tr> <td> </td> <td> </td> </tr> </table> <table border="1"> <tr> <td></td> <td style="text-align: center;">Type</td> </tr> <tr> <td style="text-align: center;">-</td> <td>Normally open</td> </tr> <tr> <td style="text-align: center;">-</td> <td>Normally closed</td> </tr> </table>	_ E H					Type	-	Normally open	-	Normally closed	-						
_ E H																				
	Type																			
-	Normally open																			
-	Normally closed																			

### 3.6 Communications setting mode

	Character	Designation	Description	Initial value						
1	EEE E	"Select the setting mode" screen Communications parameter mode	Makes settings concerning communications parameters.							
2	EEEE	Set a communications protocol	<table border="1"> <tr> <td style="width: 10px;">E</td> <td>Special-purpose protocol</td> </tr> <tr> <td>E</td> <td>MODBUS (RTU)</td> </tr> <tr> <td>E</td> <td>MODBUS (ASCII)</td> </tr> </table>	E	Special-purpose protocol	E	MODBUS (RTU)	E	MODBUS (ASCII)	E
E	Special-purpose protocol									
E	MODBUS (RTU)									
E	MODBUS (ASCII)									

	DWG No. 46-7635-C	PAGE 14/16
--	----------------------	---------------

	Character	Designation	Description	Initial value																												
3	EEEE	Set the communications parameters	<table border="1" style="margin-bottom: 5px;"> <tr><td>EEEE</td></tr> <tr><td>*</td></tr> </table> <p>BCC check</p> <table border="1" style="margin-bottom: 5px;"> <tr><td></td><td>Type</td></tr> <tr><td>E</td><td>Disable</td></tr> <tr><td>E</td><td>Enable</td></tr> </table> <p>Select a data length</p> <table border="1" style="margin-bottom: 5px;"> <tr><td>*</td><td>Type</td></tr> <tr><td>E</td><td>7 bits</td></tr> <tr><td>E</td><td>8 bits</td></tr> </table> <p>Parity check</p> <table border="1" style="margin-bottom: 5px;"> <tr><td></td><td>Type</td></tr> <tr><td>E</td><td>Disable</td></tr> <tr><td>E</td><td>Odd number</td></tr> <tr><td>E</td><td>Even number</td></tr> </table> <p>Stop bit length</p> <table border="1" style="margin-bottom: 5px;"> <tr><td></td><td>Type</td></tr> <tr><td>E</td><td>1 bit</td></tr> <tr><td>E</td><td>2 bits</td></tr> </table> <ul style="list-style-type: none"> <li>• Selecting MODBUS (RTU) enables only <u>E</u>H, <u>EE</u>, and <u>EE</u> to be selected.</li> <li>• Selecting MODBUS (ASCII) enables only <u>EE</u>, <u>EE</u>, and <u>EE</u> to be selected.</li> </ul> <p>The BCC check becomes inactive.</p>	EEEE	*		Type	E	Disable	E	Enable	*	Type	E	7 bits	E	8 bits		Type	E	Disable	E	Odd number	E	Even number		Type	E	1 bit	E	2 bits	EEEE
EEEE																																
*																																
	Type																															
E	Disable																															
E	Enable																															
*	Type																															
E	7 bits																															
E	8 bits																															
	Type																															
E	Disable																															
E	Odd number																															
E	Even number																															
	Type																															
E	1 bit																															
E	2 bits																															
4	EEEE	Set a communications speed	<table border="1" style="margin-bottom: 5px;"> <tr><td>EE</td><td>1200 bps</td></tr> <tr><td>EE</td><td>2400 bps</td></tr> <tr><td>EE</td><td>4800 bps</td></tr> <tr><td>EE</td><td>9600 bps</td></tr> <tr><td>EEE</td><td>19200 bps</td></tr> </table>	EE	1200 bps	EE	2400 bps	EE	4800 bps	EE	9600 bps	EEE	19200 bps	EE																		
EE	1200 bps																															
EE	2400 bps																															
EE	4800 bps																															
EE	9600 bps																															
EEE	19200 bps																															
5	EEEE	Communications address	Setting range: Special-purpose protocol...1 to 99 stations MODBUS...1 to 247 stations	E																												
6	EEEE	Response delay	Setting range: 0 to 250ms	E																												
7	EEEE	Set communications mode switchover	<table border="1" style="margin-bottom: 5px;"> <tr><td><u>E</u></td><td>Enable communications R</td></tr> <tr><td><u>E</u></td><td>Enable communications RW</td></tr> </table> <p>For MODBUS, the changeover setting is disabled.</p>	<u>E</u>	Enable communications R	<u>E</u>	Enable communications RW	EE																								
<u>E</u>	Enable communications R																															
<u>E</u>	Enable communications RW																															

### 3.7 Transmission output setting mode

	Character	Designation	Description	Initial value						
1	EEE E	“Select the setting mode” screen Transmission output parameter mode	Making settings concerning transmission output parameter							
2	_EEH	Set a transmission output function	<table border="1"> <thead> <tr> <th></th> <th>Type</th> </tr> </thead> <tbody> <tr> <td>E</td> <td>Disable</td> </tr> <tr> <td>E</td> <td>PV (measurement) output</td> </tr> </tbody> </table>		Type	E	Disable	E	PV (measurement) output	E
	Type									
E	Disable									
E	PV (measurement) output									
3	_EEH	Set forward/reverse action switchover for transmission output	<table border="1"> <thead> <tr> <th></th> <th>Action type</th> </tr> </thead> <tbody> <tr> <td>E</td> <td>Forward action</td> </tr> <tr> <td>E</td> <td>Reverse action</td> </tr> </tbody> </table>		Action type	E	Forward action	E	Reverse action	E
	Action type									
E	Forward action									
E	Reverse action									
4	_EEH	Set a upper limit for transmission output scaling	Model with thermocouple and resistance bulb Setting range: Lower limit to the upper limit in the setting range Provided that there shall be a difference of at least 50 digits from the lower limit in transmission output scaling. Setting unit: °C	EEED						
			Model with current and voltage Setting range: -1999 to 9999 (decimal place at a specified position) Provided that there shall be a difference of at least 50 digits from the lower limit in transmission output scaling. Setting unit: digit	EEED						
5	_EEH	Set a lower limit for transmission output scaling	Model with thermocouple and resistance bulb Setting range: Lower limit to the upper limit in the setting range Provided that there shall be a difference of at least 50 digits from the upper limit in transmission output scaling. Setting unit: °C	E						
			Model with current and voltage Setting range: -1999 to 9999 (decimal place at a specified position) Provided that there shall be a difference of at least 50 digits from the upper limit in transmission output scaling. Setting unit: digit	EEED						

## 4. Transition to the blind setting mode

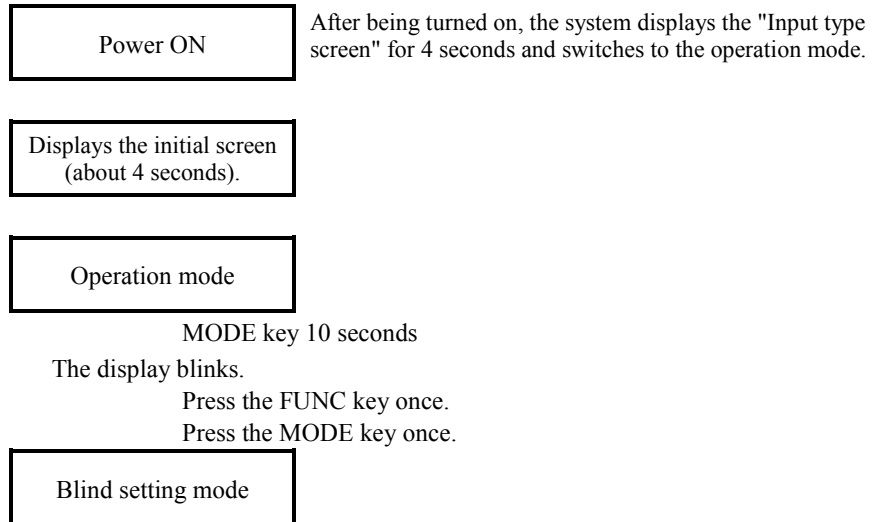

Reset the power to terminate the blind setting mode.

Use of the  key in blind setting: Selection to be made, using the "<<<" key

a) To blind (no display): **EEE**

b) No blind (display): **E**

## 5. Other displays



Displayed when the input exceeds the upper limit for the display range.  
Displayed when the thermocouple has a wire break.

Displayed when either A, B, or b terminals has a wire break in the resistance bulb.



Displayed when the input goes below the lower limit for the display range.  
Displayed when the input of 1 to 5V DC and 4 to 20 mA has a wire break.

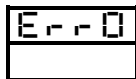

Displayed when there is a memory error.

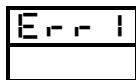

Displayed when there is an A/D conversion error.



Displayed when an attempt is made to change a parameter when the keys are locked.