

# RE12D

## OPTICAL ENCODERS

### FEATURES

- $\phi 12$  mm, 2 phases square wave
- High resolution 100 to 300 P/R
- Low torque, low inertia
- Cost effective
- RoHS compliant

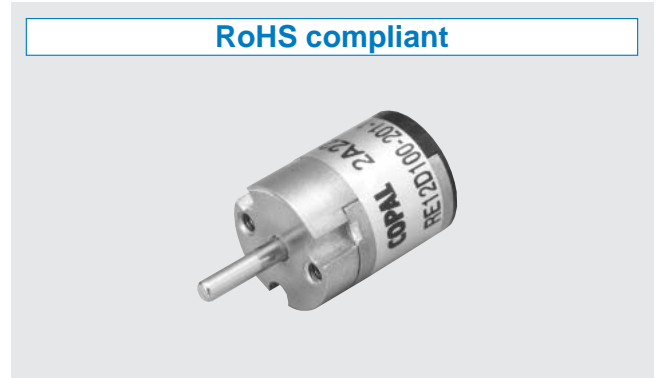

### PART NUMBER DESIGNATION

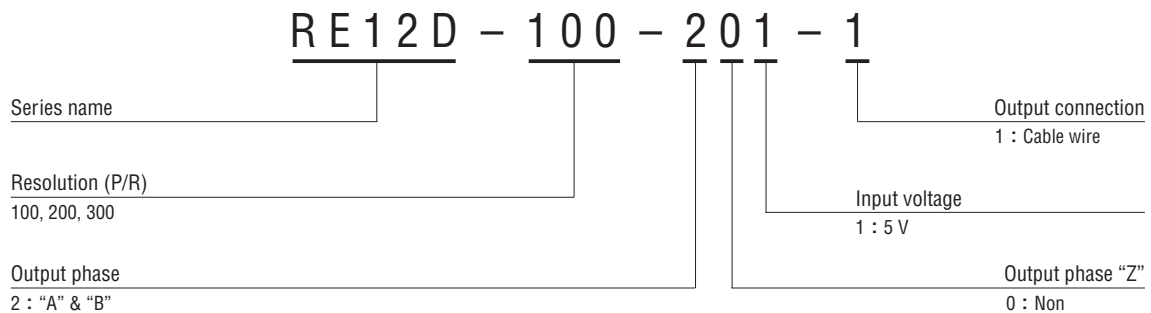

### LIST OF PART NUMBERS

Resolution	Item	Part number
100 (P/R)		RE12D-100-201-1
200 (P/R)		RE12D-200-201-1
300 (P/R)		RE12D-300-201-1

※Verify the above part numbers when placing orders.

### MECHANICAL CHARACTERISTICS

Starting torque	0.05 mN·m {0.5 gf·cm} maximum	
Inertia	0.01 g·cm <sup>2</sup>	
Shaft loading (When mounting)	Radial	1.96 N {200 gf} maximum
	Axial	1.96 N {200 gf} maximum
Net weight	10 g	

### ELECTRICAL CHARACTERISTICS

Input voltage	DC5 V $\pm$ 5 %	
Input current	50 mA maximum	
Output wave form	Square wave	
Output phases	A, B	
Resolution	100, 200, 300	
Phase difference of A & B outputs	90° $\pm$ 45°	
Maximum frequencies response	10 kHz	
Output signal	"1 (High)"	+ 4.5 V minimum
	"0 (Low)"	+ 0.5 V maximum
Output impedance	1 k $\Omega$	
Light source	LED	

### Environmental characteristics

Operating temp. range	0 ~ 50 °C	
Storage temp. range	- 20 ~ 80 °C	
Protection grade	IP - 40	

### RELIABILITY TEST

Test item		Test conditions	
Vibration	Power OFF	Amplitude : 1.52 mm or 98.1 m/s <sup>2</sup> (10 G) whichever is smaller. 10 ~ 500 Hz excursion 5 min/cycle, 1 hour each for X, Y, Z, directions.	
Shock	Power OFF	1 time each in 6 directions (X, Y, Z) at 490 m/s <sup>2</sup> (50 G), 11 ms.	
High temperature exposure	Power OFF	80 °C 96 h	(To be measured after leaving samples for 1 h at normal temperature and humidity after the test.)
	Power ON	50 °C 96 h	
Low temperature exposure	Power OFF	- 20 °C 96 h	
	Power ON	0 °C 96 h	
Humidity	Power OFF	(To be measured after wiping out moisture and leaving samples for 1 h at normal temperature and humidity after the test.)	
Thermal shock	Power OFF	To be done 5 cycles with the following condition (To be measured after leaving samples for 1 h at normal temperature and humidity after the test.) 70 °C 0.5 h、- 20 °C 0.5 h	

### OUTPUT

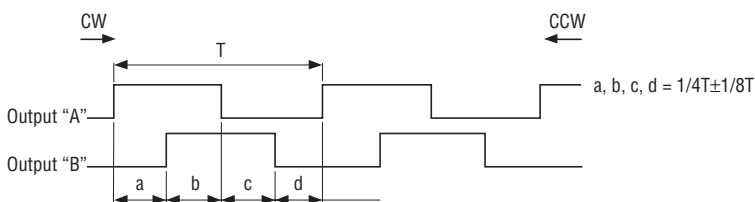

### OUTPUT CIRCUIT

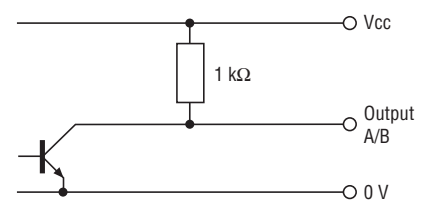

### OUTLINE DIMENSIONS

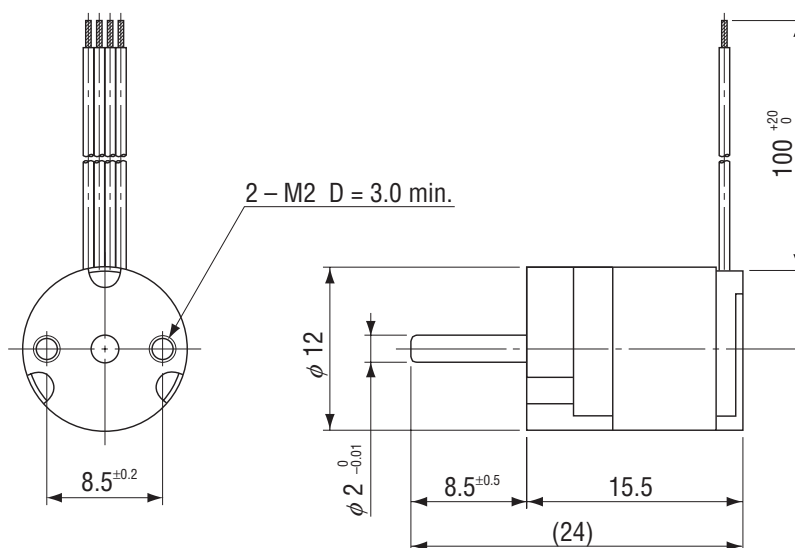

Unless otherwise specified, tolerance :  $\pm 0.4$  (Unit : mm)

### ELECTRICAL WIRING

Red	Power (+)
Black	Power 0 (V)
White	Output "A"
Green	Output "B"