

PA-830

PRESSURE TRANSDUCERS WITH AMP.



FEATURES

- High corrosion resistance by double diaphragm structure
- Built-in amplifier circuit
- 2 types to choose from (Gauge and Absolute pressures)
- Incorporating temperature compensation function (0 ~ 50 °C)
- Voltage output mode
- Available with a *VCR® fitting

INTERNAL STRUCTURE
PA-830 (G 1/8)

Part name	Material
① Fitting	SUS 316L
② "O" ring (P15 or P12.5)	Fluoro-rubber
③ Housing	Aluminum
④ Compensation resistor board	Ceramic
⑤ Sealed liquid	Silicone oil

MODEL NUMBER DESIGNATION

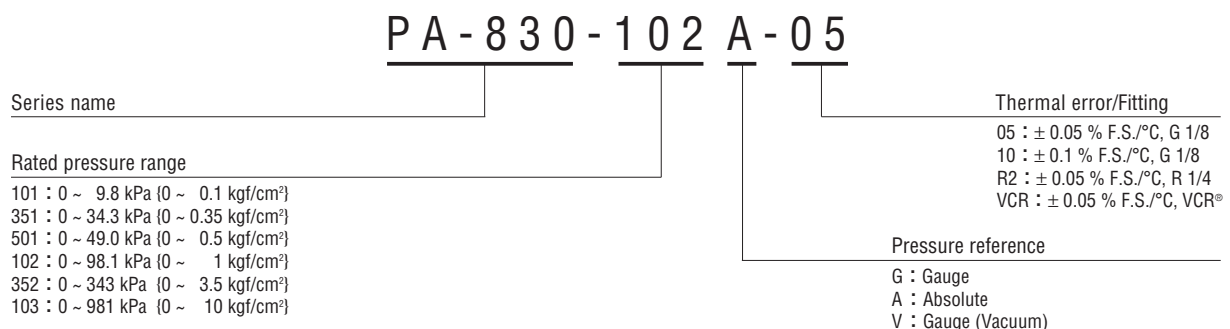

※ Please refer to the LIST OF MODEL NUMBERS when placing orders.

※ VCR® is a registered trade name of Cajon Co. CAJON® is a registered trade name of Swagelok Co.

Note: For handling of VCR fittings, please contact a service center of Swagelok Co.

PA-830 PRESSURE TRANSDUCERS WITH AMP.

LIST OF MODEL NUMBERS

Output	Pressure reference		Gauge						Absolute	
	Thermal error {% F.S./°C}	kPa {kgf/cm ² } Rated pressure range	0 ~ 9.8 {0 ~ 0.1}	0 ~ 49.0 {0 ~ 0.5}	0 ~ 98.1 {0 ~ 1}	0 ~ 343 {0 ~ 3.5}	0 ~ 981 {0 ~ 10}	0 ~ -98.1 {0 ~ -1}	0 ~ 34.3 {0 ~ 0.35}	0 ~ 98.1 {0 ~ 1}
Voltage output	± 0.05	Fitting : G 1/8	PA-830-501G-05	PA-830-102G-05	PA-830-352G-05	PA-830-103G-05	PA-830-102V-05	PA-830-351A-05	PA-830-102A-05	
		Fitting : R 1/4	PA-830-501G-R2	PA-830-102G-R2	PA-830-352G-R2	PA-830-103G-R2	PA-830-102V-R2	PA-830-351A-R2	PA-830-102A-R2	
		Fitting : VCR	PA-830-501G-VCR	PA-830-102G-VCR	PA-830-352G-VCR	PA-830-103G-VCR	PA-830-102V-VCR	PA-830-351A-VCR	PA-830-102A-VCR	
	± 0.10	Fitting : G 1/8	PA-830-101G-10	PA-830-501G-10	PA-830-102G-10	PA-830-352G-10	PA-830-103G-10	PA-830-102V-10	PA-830-351A-10	PA-830-102A-10

☐ : Not available

※Verify the above model numbers when placing orders.

STANDARD SPECIFICATIONS

●Unless otherwise specified, the specs are defined at an ambient temperature of 25±5 °C and excitation voltage of 12 V DC.

Item	Model number	PA-830								
		101G	501G	102G	352G	103G	102V	351A	102A	
General specifications	Pressure reference	Gauge						Absolute		
	Rated pressure range	kPa {kgf/cm ² }	9.8 {0.1}	49.0 {0.5}	98.1 {1}	343 {3.5}	981 {10}	-98.1 {-1}	34.3 (abs) {0.35}	98.1 (abs) {1}
	Maximum pressure	kPa {kgf/cm ² }	19.6 {0.2}	98.1 {1}	196 {2}	686 {7}	1961 {20}	196 {2}	103 (abs) {1.05}	196 (abs) {2}
	Break-down pressure	kPa {kgf/cm ² }	29.4 {0.3}	147 {1.5}	294 {3}	1030 {10.5}	2942 {30}	294 {3}	147 (abs) {1.5}	294 (abs) {3}
	Operating temp. range	°C	-20 ~ 70							
	Compensated temp. range	°C	0 ~ 50							
	Operating humidity	%RH	35 ~ 85 (No condensation)							
	Storage temp.	°C	-20 ~ 70 (Atmospheric pressure, humidity 65 %RH maximum)							
	Pressure medium		Corrosive gases/liquids compatible with SUS 316L ※1							
	Insulation resistance	MΩ minimum	100 (500 V DC)							
	Dielectric strength		500 V AC, 60 s (Leakage current 1 mA maximum)							
	Sealed liquid		Silicone oil							
	Pressure port		G 1/8 (PF 1/8), R 1/4 (PT 1/4), 1/4 VCR® ※2							
	Net weight	g	Approx. 140							
Power	Supply voltage	V DC	12 ~ 24 ± 10 %							
	Ripple content	maximum	10 % (P-P)							
	Consumption current	mA maximum	20							

※1 PA-830-VCR : Also compatible with SUS316.

※2 An "O" ring is provided for only G1/8 type. (Positive pressure : P15, Negative/Absolute Pressure : P12.5)

PA-830 PRESSURE TRANSDUCERS WITH AMP.

Item	Model number	PA-830								
		101G	501G	102G	352G	103G	102V	351A	102A	
Analog output	Output voltage	V DC	1 ~ 5							
	Zero voltage	V	1 ± 0.04 (at 25 °C)							
	Span voltage	V	4 ± 0.04 (at 25 °C)							
	Output current	mA maximum	1 (Load resistance 5 kΩ minimum)							
	Linearity/Hysteresis	%F.S.	± 0.5	± 0.3		± 0.5	± 0.3		± 0.5	
	Thermal error 0 ~ 50 °C (Reference temp.: 25 °C)	ZERO	± 0.05/± 0.1 ※3							
		SPAN	± 0.05/± 0.1 ※3							
	Supply voltage effect	V maximum	± 0.1							
	Response	ms	Approx. 2							
Gravitational effect (From vertical position to horizontal position)	%F.S. max.	Approx. 1	Approx. 0.5	Approx. 0.3	Approx. 0.1	Approx. 0.05	Approx. 0.3	Approx. 0.5	Approx. 0.3	

※3 The thermal error of the PA-830-101G will be ± 0.1 %F.S./°C only.

ENVIRONMENTAL CHARACTERISTICS

Test item	Test conditions (At 25 ± 5 °C)	Permissible change
Vibration	10 ~ 500 Hz, 1.5 mm maximum/98.1 m/s ² , 3 directions for 2 hours each	Zero voltage, Span voltage: ± 1 %F.S. maximum each
Shock	490 m/s ² , 3 directions for 3 times each	
Pressure cycling	0 ~ Rated pressure, 10 ⁶ cycles	
Moisture resistance	40 °C, 90 ~ 95 %RH, 240 hrs.	

INTERNAL ELECTRICAL SCHEMATICS

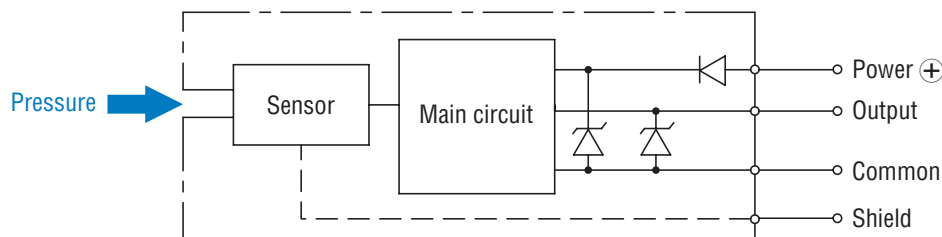

PA-830 PRESSURE TRANSDUCERS WITH AMP.

OUTLINE DIMENSIONS

Unless otherwise specified, tolerance : ± 0.5 (Unit: mm)

● G1/8 type

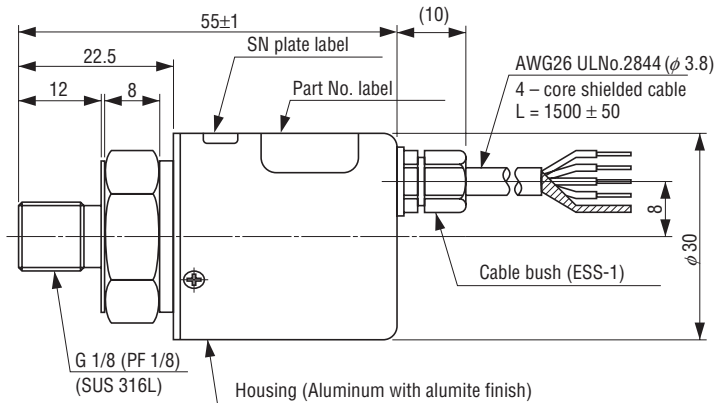
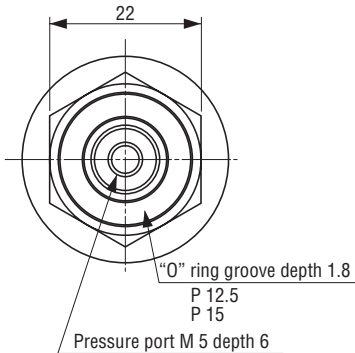

PA-830

Wire color	Connection
Red	Power ⊕
White	Output
Green	N.C.
Black	Common
Shield	Fitting

● R1/4 type

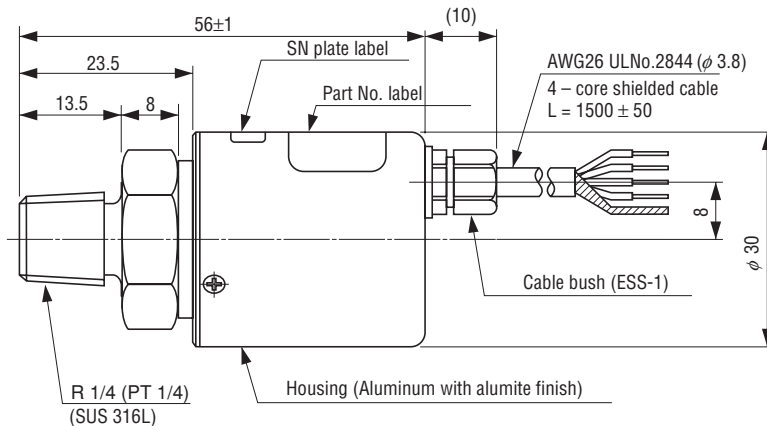
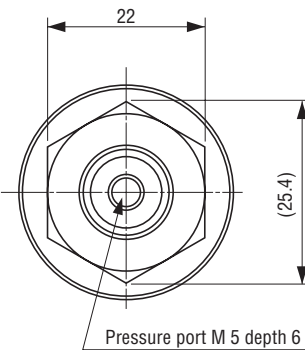

● VCR type

